

EHV Power Cable Systems

Power Cables

Cable Accessories

Cable Monitoring & Maintenance Systems



ILJIN Electric is a global leader in the heavy electrical industry providing the best products and services with cutting edge technology of world class and competitiveness.





We, ILJIN Electric Co. Ltd., founded in 1968, are one of companies in ILJIN Group that provides new materials and total solution to the power transmission & distribution industry. Since our commencement, we have experienced substantial growth fueled by our desire to become “your total solution provider for the 21st century”. Moreover, we continue to increase our market share in the high-tech sector based on our 100% technological self-reliance.

Since 1994, our Cable Division has been manufacturing, assembling and installing the Extra High Voltage(EHV) cables and accessories. By providing world class cable networks in the power industry, we have also been playing a pivotal role as the backbone of a nation's key industries.

ILJIN Electric will endeavour to elevate our status as a global company by successfully carrying out various projects over 30 countries around the world. We aim to create customer value through best service, technology, passion and innovation.

Our main products include overhead transmission line, insulated wire, medium/low voltage cable, special cable, (Extra) high voltage cable and accessories.



Index

1. Cable Design & Construction
2. Manufacturing process & Facility
3. EHV XLPE insulated cable
4. Accessories for EHV cable system
5. Quality Assurance system
6. Cable Monitoring & Maintenance system
7. Cable Installation & System Design
8. Current Status of R&D

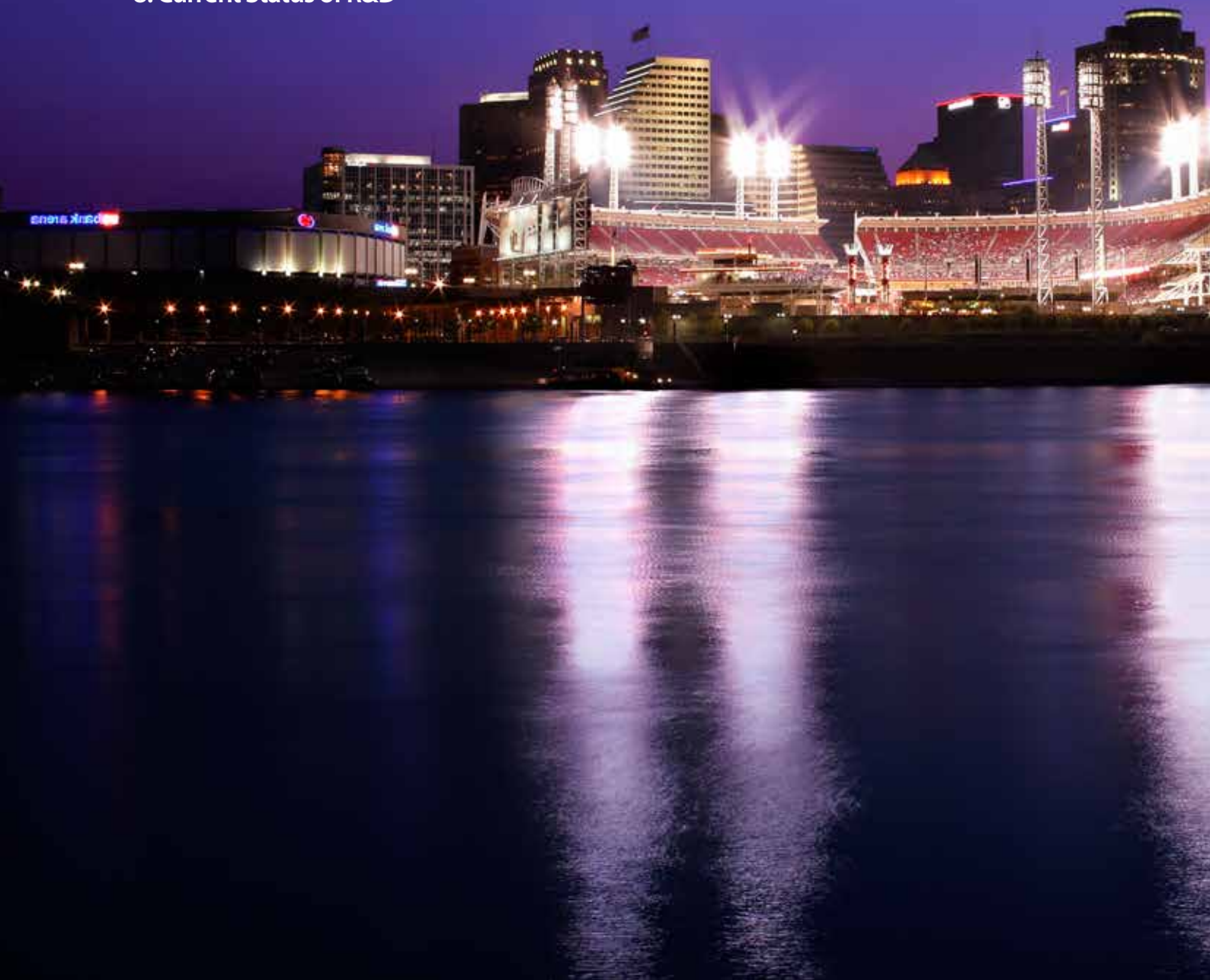

1. Cable Design & Construction

As per IEC standard the power cable is designed and manufactured with following construction ;

The maximum conductor temperature is ;

• Normal operation : 90°C

• Short circuit operation : 250°C



1. Conductor

The conductor consists of annealed copper or hard drawn aluminum stranded wire and be circular stranded, circular compact stranded, circular compressed or segmental compact stranded. The segmental compact stranded construction shall be used for the conductor with area greater than or equal to 800mm². Specially the enameled copper wire shall be used to reduce the skin & proximity effect of conductor. If necessary, semi-conducting binder tape may be applied on the conductor.

2. Conductor screen

The conductor screen consists of an extruded layer of thermosetting semi-conducting compound and shall be continuous and cover the whole surface area of the conductor. The conductor screen shall be firmly bonded to the insulation. The outer surface of the conductor screen shall be circular.

3. Insulation

The insulation is an extruded cross-linked polyethylene (XLPE). The insulation shall be applied by extrusion and vulcanized to form a compact homogenous body free of microvoids and contaminants. The insulation shall be extruded with conductor screen and insulation screen layer simultaneously. The insulation thickness shall be designed by critical impulse and AC withstand voltage.

4. Insulation screen

The insulation screen consists of an extruded layer of thermosetting semi-conducting compound and shall be continuous and cover the whole surface area of the insulation. The insulation screen shall be firmly bonded to the insulation.

5. Metal sheath

The metal sheath consists of copper wire, lead alloy, corrugated aluminum, corrugated copper or smoothed aluminum over insulation screen. The metal sheath shall be designed to meet the required earth fault current.

6. Outer sheath

The outer sheath consists of an extruded layer of polyethylene or polyvinyl chloride compound.

2. Manufacturing Process & Facility

Flow chart of manufacturing process

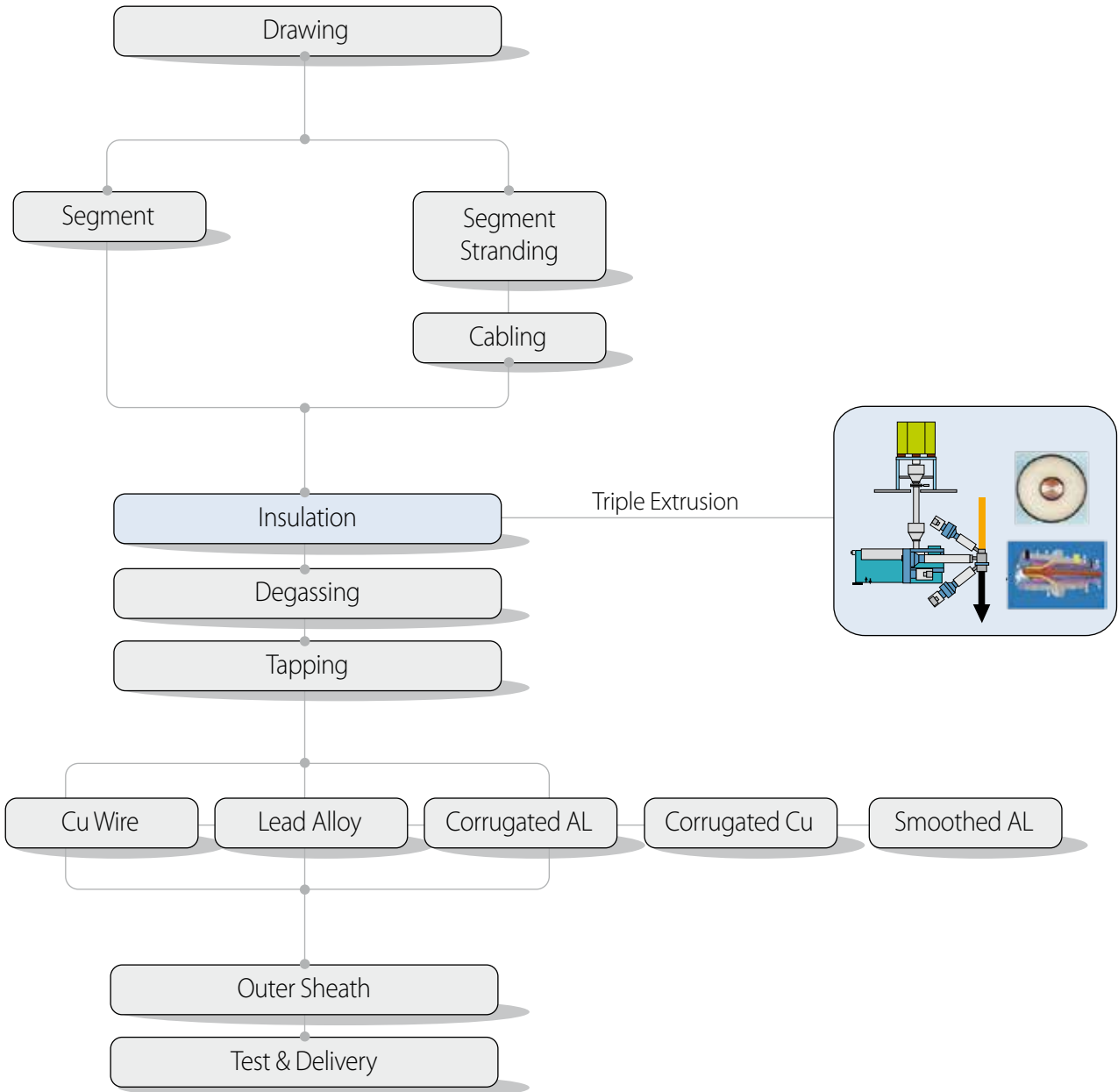

VCV Line

Due to the eccentricity of the insulation of EHV cables, VCV (Vertical Continuous Vulcanizing) line is used during products process.

Nitrogen gas is used during the cross linking process for the excellence of the electrical characteristics. Furthermore, the conductor screen, insulation and insulation screen are extruded simultaneously to prevent creation of micro-voids and irregularities.

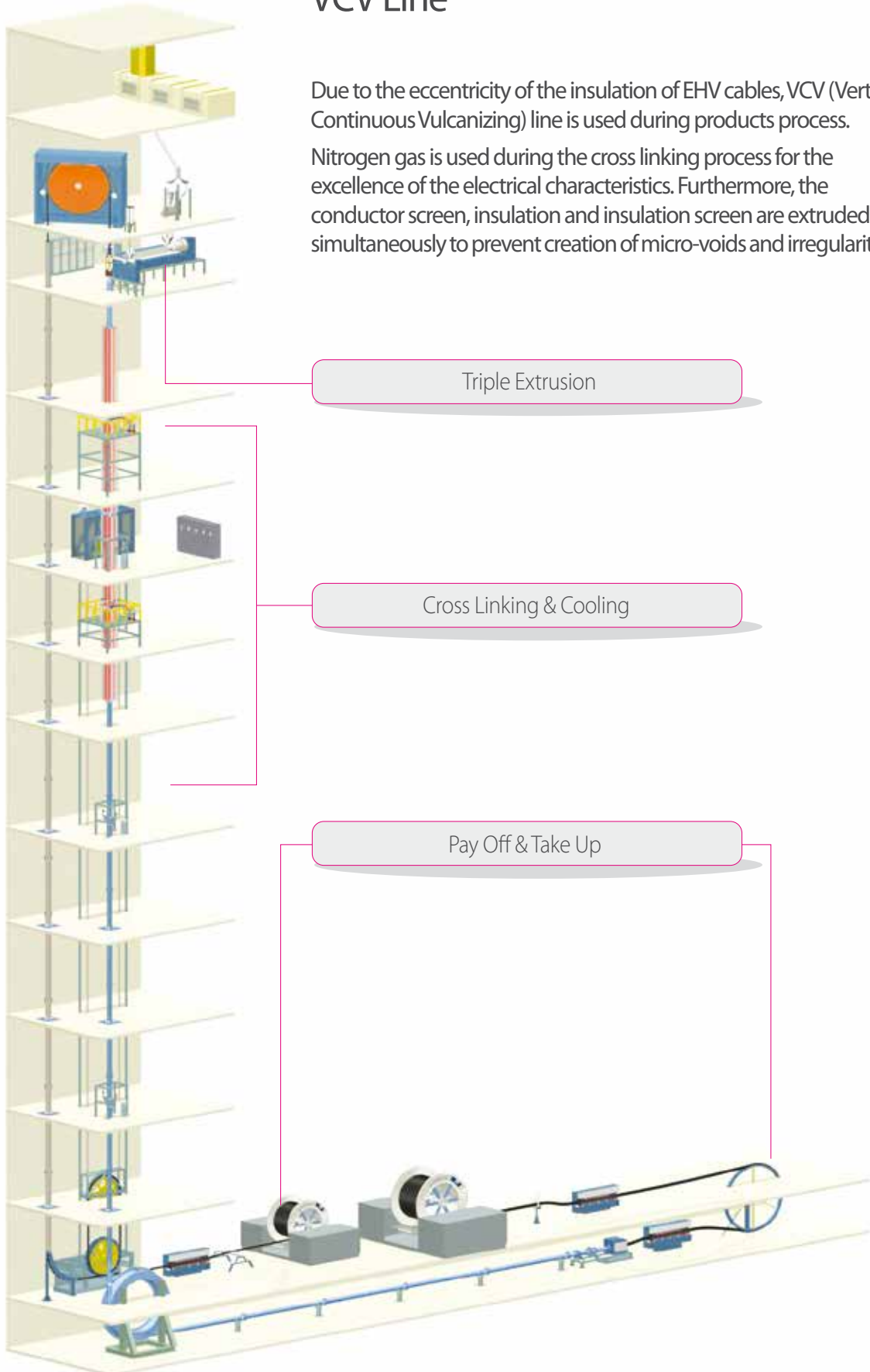

Triple Extrusion

Cross Linking & Cooling

Pay Off & Take Up





3. EHV XLPE Insulated cable

60~69kV XLPE Cable with Corrugated Aluminum Sheath	10
60~69kV XLPE Cable with copper wire screen	11
60~69kV XLPE Cable with Lead alloy Sheath	12
60~69kV XLPE Cable with Smoothed Aluminum Sheath	13
110~115kV XLPE Cable with Corrugated Aluminum Sheath	14
110~115kV XLPE Cable with copper wire screen	15
110~115kV XLPE Cable with Lead alloy Sheath	16
110~115kV XLPE Cable with Smoothed Aluminum Sheath	17
132~138kV XLPE Cable with Corrugated Aluminum Sheath	18
132~138kV XLPE Cable with copper wire screen	19
132~138kV XLPE Cable with Lead alloy Sheath	20
132~138kV XLPE Cable with Smoothed Aluminum Sheath	21
150~161kV XLPE Cable with Corrugated Aluminum Sheath	22
150~161kV XLPE Cable with copper wire screen	23
150~161kV XLPE Cable with Lead alloy Sheath	24
150~161kV XLPE Cable with Smoothed Aluminum Sheath	25
220~230kV XLPE Cable with Corrugated Aluminum Sheath	26
220~230kV XLPE Cable with copper wire screen	27
220~230kV XLPE Cable with Lead alloy Sheath	28
220~230kV XLPE Cable with Smoothed Aluminum Sheath	29
275~287kV XLPE Cable with Corrugated Aluminum Sheath	30
275~287kV XLPE Cable with copper wire screen	31
275~287kV XLPE Cable with Lead alloy Sheath	32
275~287kV XLPE Cable with Smoothed Aluminum Sheath	33
330~345kV XLPE Cable with Corrugated Aluminum Sheath	34
330~345kV XLPE Cable with copper wire screen	35
330~345kV XLPE Cable with Lead alloy Sheath	36
330~345kV XLPE Cable with Smoothed Aluminum Sheath	37
380~400kV XLPE Cable with Corrugated Aluminum Sheath	38
380~400kV XLPE Cable with copper wire screen	39
380~400kV XLPE Cable with Lead alloy Sheath	40
380~400kV XLPE Cable with Smoothed Aluminum Sheath	41
Continuous Current Rating Capacity	42
Short Circuit Current Rating	43

66~69kV XLPE Cable with Corrugated Aluminum Sheath

Cable type : 66~69kV Cu(or AL)/XLPE/Corrugated AL/PE(or PVC)



1. Conductor : Copper or enameled copper or aluminum
2. Conductor screen : Semi-conducting compound
3. Insulation : Cross-linked polyethylene
4. Insulation screen : Semi-conducting compound
5. Cushion layer : Semi-conducting tapes
6. Metal sheath : Corrugated aluminum
7. Outer sheath : Polyethylene or polyvinyl chloride

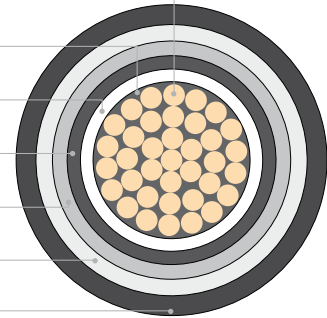

Construction Data

	Cross sectional area (mm ²)	240	300	400	500	630	800	1000	1200	1600	2000	2500	
Conductor	Shape	Circular compact stranded						Segmental stranded					
	Diameter (mm)	18.5	20.7	23.3	26.9	30.5	34.3	39.3	42.4	48.9	54.9	61.4	
Thickness of conductor screen Approx.	(mm)	1.0	1.0	1.0	1.0	1.0	1.0	1.0	1.0	1.0	1.0	1.0	
Thickness of insulation	(mm)	11.0	11.0	11.0	11.0	11.0	11.0	11.0	11.0	11.0	11.0	11.0	
Thickness of insulation screen Approx.	(mm)	1.0	1.0	1.0	1.0	1.0	1.0	1.0	1.0	1.0	1.0	1.0	
Thickness of metal sheath	(mm)	1.6	1.7	1.7	1.8	1.9	1.9	2.0	2.1	2.2	2.4	2.5	
Thickness of outer sheath	(mm)	3.5	3.5	3.5	3.5	3.5	3.5	4.0	4.0	4.0	4.0	4.0	
Outer diameter of cable	(mm)	77.0	79.0	82.0	86.0	89.0	93.0	100.0	104.0	111.0	118.0	125.0	
Weight of cable(Copper conductor)	(kg/m)	5.9	6.7	7.7	9.0	10.7	12.7	15.5	17.5	21.9	26.5	31.9	
Weight of cable(Aluminum conductor)	(kg/m)	4.4	4.8	5.3	5.9	6.7	7.5	8.9	9.8	11.6	13.5	15.2	
Max. DC Conductor resistance at 20°C	(Cu, Ω/km)	0.0754	0.0601	0.047	0.0366	0.0283	0.0221	0.0176	0.0151	0.0113	0.009	0.0072	
Max. DC Conductor resistance at 20°C	(AL, Ω/km)	0.125	0.100	0.0778	0.0605	0.0469	0.0367	0.0291	0.0247	0.0186	0.0149	0.0127	
Capacitance	(μF/km)	0.19	0.21	0.22	0.25	0.27	0.30	0.33	0.35	0.39	0.43	0.47	

Continuous current rating(Single circuit)

	Cross sectional area (mm ²)	240	300	400	500	630	800	1000	1200	1600	2000	2500
Copper Conductor	In air (A)	598	682	783	902	1029	1157	1374	1478	1679	1826	1966
	In direct buried (A)	454	510	577	650	727	801	925	978	1076	1137	1192
	In duct (A)	457	514	599	680	769	858	996	1064	1242	1342	1427
Aluminium Conductor	In air (A)	467	533	617	718	829	947	1154	1212	1403	1558	1681
	In direct buried (A)	355	400	456	519	588	659	779	809	909	982	1034
	In duct (A)	355	400	469	536	611	690	820	854	1006	1106	1174

* Enameled conductor Increasing current capacity approx. 10~13%

66~69kV XLPE Cable with Copper Wire Screen

Cable type : 66~69kV Cu(or AL)/XLPE/CWS/PE (or PVC)



1. Conductor : Copper or enameled copper or aluminum
2. Conductor screen : Semi-conducting compound
3. Insulation : Cross-linked polyethylene
4. Insulation screen : Semi-conducting compound
5. Cushion layer : Semi-conducting tapes
6. Metalc screen : Copper wires
7. Water blocking layer : Plastic laminted aluminum foil
8. Outer sheath : Polyethylene or polyvinyl chloride

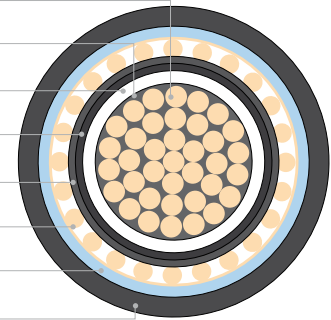

Construction Data

Cross sectional area (mm ²)		240	300	400	500	630	800	1000	1200	1600	2000	2500	
Conductor	Shape	Circular compact stranded						Segmental stranded					
	Diameter (mm)	18.5	20.7	23.3	26.9	30.5	34.3	39.3	42.4	48.9	54.9	61.4	
Thickness of conductor screen Approx. (mm)		1.0	1.0	1.0	1.0	1.0	1.0	1.0	1.0	1.0	1.0	1.0	
Thickness of insulation (mm)		11.0	11.0	11.0	11.0	11.0	11.0	11.0	11.0	11.0	11.0	11.0	
Thickness of insulation screen Approx. (mm)		1.0	1.0	1.0	1.0	1.0	1.0	1.0	1.0	1.0	1.0	1.0	
Dia. x No. of metal screen (mmxEA)		1.2 x 40	1.2 x 40	1.2 x 40	1.2 x 40	1.2 x 40	1.2 x 40	1.2 x 40	1.2 x 40	1.2 x 40	1.2 x 40	1.2 x 40	
Thickness of outer sheath (mm)		3.5	3.5	3.5	3.5	3.5	3.5	4.0	4.0	4.0	4.0	4.0	
Outer diameter of cable (mm)		58.0	61.0	64.0	67.0	70.0	75.0	81.0	84.0	90.0	96.0	103.0	
Weight of cable(Copper conductor) (kg/m)		4.8	5.4	6.4	7.5	9.0	11.0	13.4	15.1	19.2	23.3	28.3	
Weight of cable(Aluminum conductor) (kg/m)		3.3	3.6	4.0	4.4	5.0	5.8	6.7	7.4	8.9	10.3	11.6	
Max. DC Conductor resistance at 20°C (Cu, Ω/km)		0.0754	0.0601	0.047	0.0366	0.0283	0.0221	0.0176	0.0151	0.0113	0.009	0.0072	
Max. DC Conductor resistance at 20°C (AL, Ω/km)		0.125	0.100	0.0778	0.0605	0.0469	0.0367	0.0291	0.0247	0.0186	0.0149	0.0127	
Capacitance (μF/km)		0.19	0.21	0.22	0.25	0.27	0.30	0.33	0.35	0.39	0.43	0.47	

Continuous current rating(Single circuit)

Cross sectional area (mm ²)		240	300	400	500	630	800	1000	1200	1600	2000	2500
Copper Conductor	In air (A)	603	690	795	921	1058	1200	1460	1592	1859	2082	2307
	In direct buried (A)	457	515	584	662	746	830	985	1059	1203	1317	1425
	In duct (A)	457	515	585	665	774	867	1015	1094	1251	1419	1547
Aluminium Conductor	In air (A)	470	537	624	729	847	973	1207	1276	1510	1717	1892
	In direct buried (A)	356	402	459	525	598	674	813	851	980	1089	1172
	In duct (A)	355	401	458	523	613	693	830	868	1001	1145	1235

* Enameled conductor Increasing current capacity approx. 10~13%

66~69kV XLPE Cable with Lead alloy Sheath

Cable type : 66~69kV Cu(or AL)/XLPE/Lead alloy/PE(or PVC)



1. Conductor : Copper or enameled copper or aluminum
2. Conductor screen : Semi-conducting compound
3. Insulation : Cross-linked polyethylene
4. Insulation screen : Semi-conducting compound
5. Cushion layer : Semi-conducting tapes
6. Metal sheath : Lead alloy
7. Outer sheath : Polyethylene or polyvinyl chloride

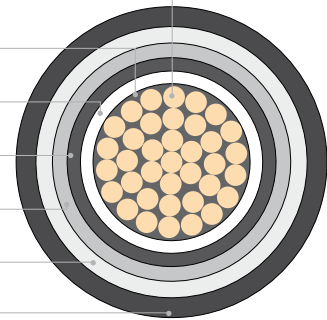

Construction Data

Cross sectional area (mm ²)		240	300	400	500	630	800	1000	1200	1600	2000	2500
Conductor	Shape	Circular compact stranded						Segmental stranded				
	Diameter (mm)	18.5	20.7	23.3	26.9	30.5	34.3	39.3	42.4	48.9	54.9	61.4
Thickness of conductor screen Approx. (mm)		1.0	1.0	1.0	1.0	1.0	1.0	1.0	1.0	1.0	1.0	1.0
Thickness of insulation (mm)		11.0	11.0	11.0	11.0	11.0	11.0	11.0	11.0	11.0	11.0	11.0
Thickness of insulation screen Approx. (mm)		1.0	1.0	1.0	1.0	1.0	1.0	1.0	1.0	1.0	1.0	1.0
Thickness of metal sheath (mm)		2.1	2.1	2.2	2.3	2.4	2.5	2.6	2.8	3.0	3.2	3.4
Thickness of outer sheath (mm)		3.5	3.5	3.5	3.5	3.5	3.5	4.0	4.0	4.0	4.0	4.0
Outer diameter of cable (mm)		66.0	68.0	71.0	75.0	79.0	83.0	90.0	93.0	100.0	106.0	113.0
Weight of cable(Copper conductor) (kg/m)		8.5	9.5	10.8	12.4	14.4	16.9	20.4	23.0	28.4	33.8	40.3
Weight of cable(Aluminum conductor) (kg/m)		7.0	7.6	8.3	9.3	10.4	11.7	13.7	15.3	18.1	20.8	23.6
Max. DC Conductor resistance at 20°C (Cu, Ω/km)		0.0754	0.0601	0.047	0.0366	0.0283	0.0221	0.0176	0.0151	0.0113	0.009	0.0072
Max. DC Conductor resistance at 20°C (AL, Ω/km)		0.125	0.100	0.0778	0.0605	0.0469	0.0367	0.0291	0.0247	0.0186	0.0149	0.0127
Capacitance (μF/km)		0.19	0.21	0.22	0.25	0.27	0.30	0.33	0.35	0.39	0.43	0.47

Continuous current rating(Single circuit)

Cross sectional area (mm ²)		240	300	400	500	630	800	1000	1200	1600	2000	2500
Copper Conductor	In air (A)	606	693	800	927	1067	1211	1471	1603	1867	2082	2290
	In direct buried (A)	462	521	591	671	757	842	1000	1073	1214	1321	1418
	In duct (A)	461	520	591	672	782	877	1027	1107	1265	1433	1557
Aluminium Conductor	In air (A)	472	540	628	733	853	981	1216	1286	1519	1721	1888
	In direct buried (A)	359	406	464	531	605	683	825	862	991	1097	1175
	In duct (A)	358	404	462	528	619	701	840	879	1013	1158	1247

* Enameled conductor Increasing current capacity approx. 10~13%

66~69kV XLPE Cable with Smoothed Aluminum Sheath

Cable type : 66~69kV Cu(or AL)/XLPE/Smoothed AL/PE(or FR-PE)



1. Conductor : Copper or enameled copper or aluminum
2. Conductor screen : Semi-conducting compound
3. Insulation : Cross-linked polyethylene
4. Insulation screen : Semi-conducting compound
5. Cushion layer : Semi-conducting tapes
6. Metal sheath : Smoothed aluminum
7. Outer sheath : Polyethylene or Flame retardant polyethylene

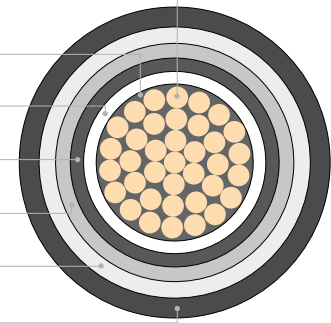

Construction Data

	Cross sectional area (mm ²)	240	300	400	500	630	800	1000	1200	1600	2000	2500	
Conductor	Shape	Circular compact stranded						Segmental stranded					
	Diameter (mm)	18.5	20.7	23.3	26.9	30.5	34.3	39.3	42.4	48.9	54.9	61.4	
Thickness of conductor screen Approx. (mm)		1.0	1.0	1.0	1.0	1.0	1.0	1.0	1.0	1.0	1.0	1.0	
Thickness of insulation (mm)		11.0	11.0	11.0	11.0	11.0	11.0	11.0	11.0	11.0	11.0	11.0	
Thickness of insulation screen Approx. (mm)		1.0	1.0	1.0	1.0	1.0	1.0	1.0	1.0	1.0	1.0	1.0	
Thickness of metal sheath (mm)		2.5	2.4	2.3	2.1	2.0	1.9	1.7	1.7	1.5	1.4	1.3	
Thickness of outer sheath (mm)		3.5	3.5	3.5	3.5	3.5	3.5	4.0	4.0	4.0	4.0	4.0	
Outer diameter of cable (mm)		62.0	64.0	66.0	69.0	73.0	76.0	83.0	86.0	92.0	98.0	104.0	
Weight of cable(Copper conductor) (kg/m)		5.2	5.9	6.7	7.9	9.4	11.2	13.7	15.5	19.5	23.6	28.6	
Weight of cable(Aluminum conductor) (kg/m)		3.7	4.0	4.3	4.8	5.4	6.0	7.1	7.8	9.2	10.6	11.9	
Max. DC Conductor resistance at 20°C (Cu, Ω/km)		0.0754	0.0601	0.047	0.0366	0.0283	0.0221	0.0176	0.0151	0.0113	0.009	0.0072	
Max. DC Conductor resistance at 20°C (AL, Ω/km)		0.125	0.100	0.0778	0.0605	0.0469	0.0367	0.0291	0.0247	0.0186	0.0149	0.0127	
Capacitance (μF/km)		0.19	0.21	0.22	0.25	0.27	0.30	0.33	0.35	0.39	0.43	0.47	

Continuous current rating(Single circuit)

	Cross sectional area (mm ²)	240	300	400	500	630	800	1000	1200	1600	2000	2500
Copper Conductor	In air (A)	600	683	784	902	1030	1159	1389	1504	1727	1909	2088
	In direct buried (A)	455	510	576	649	726	801	934	997	1111	1198	1279
	In duct (A)	459	517	603	685	775	866	1009	1085	1273	1395	1507
Aluminium Conductor	In air (A)	469	535	619	720	832	951	1165	1229	1437	1615	1764
	In direct buried (A)	356	401	456	520	589	660	786	820	931	1022	1090
	In duct (A)	357	403	471	539	613	695	829	866	1024	1136	1220

* Enameled conductor Increasing current capacity approx. 10~13%

110~115kV XLPE Cable with Corrugated Aluminum Sheath

Cable type : 110~115kV Cu(or AL)/XLPE/Corrugated AL/PE(or PVC)



1. Conductor : Copper or enameled copper or aluminum
2. Conductor screen : Semi-conducting compound
3. Insulation : Cross-linked polyethylene
4. Insulation screen : Semi-conducting compound
5. Cushion layer : Semi-conducting tapes
6. Metal sheath : Corrugated aluminum
7. Outer sheath : Polyethylene or polyvinyl chloride

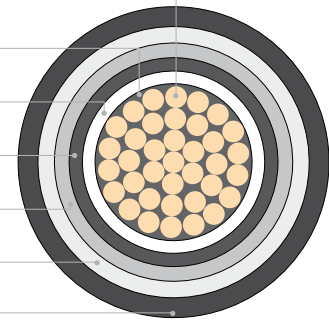

Construction Data

	Cross sectional area (mm ²)	240	300	400	500	630	800	1000	1200	1600	2000	2500	
Conductor	Shape	Circular compact stranded						Segmental stranded					
	Diameter (mm)	18.5	20.7	23.3	26.9	30.5	34.3	39.3	42.4	48.9	54.9	61.4	
Thickness of conductor screen Approx.	(mm)	1.3	1.3	1.3	1.3	1.3	1.3	1.3	1.3	1.3	1.3	1.3	
Thickness of insulation	(mm)	14.0	14.0	14.0	14.0	14.0	14.0	14.0	14.0	14.0	14.0	14.0	
Thickness of insulation screen Approx.	(mm)	1.2	1.2	1.2	1.2	1.2	1.2	1.2	1.2	1.2	1.2	1.2	
Thickness of metal sheath	(mm)	1.7	1.8	1.8	1.9	2.0	2.1	2.2	2.2	2.4	2.5	2.6	
Thickness of outer sheath	(mm)	4.0	4.0	4.0	4.0	4.0	4.0	4.0	4.0	4.0	4.0	4.0	
Outer diameter of cable	(mm)	85.0	87.0	90.0	94.0	98.0	102.0	108.0	111.0	119.0	126.0	133.0	
Weight of cable(Copper conductor)	(kg/m)	7.0	7.8	8.8	10.2	11.9	14.1	16.8	18.7	23.4	27.9	33.3	
Weight of cable(Aluminum conductor)	(kg/m)	5.5	5.9	6.4	7.1	7.9	8.9	10.2	11.0	13.0	14.9	16.6	
Max. DC Conductor resistance at 20°C	(Cu, Ω/km)	0.0754	0.0601	0.047	0.0366	0.0283	0.0221	0.0176	0.0151	0.0113	0.009	0.0072	
Max. DC Conductor resistance at 20°C	(AL, Ω/km)	0.125	0.100	0.0778	0.0605	0.0469	0.0367	0.0291	0.0247	0.0186	0.0149	0.0127	
Capacitance	(μF/km)	0.17	0.18	0.19	0.21	0.23	0.25	0.28	0.29	0.32	0.36	0.39	

Continuous current rating(Single circuit)

	Cross sectional area (mm ²)	240	300	400	500	630	800	1000	1200	1600	2000	2500
Copper Conductor	In air (A)	594	676	776	892	1018	1143	1351	1456	1650	1802	1944
	In direct buried (A)	453	508	574	647	722	795	912	968	1060	1126	1182
	In duct (A)	463	522	593	672	759	844	1007	1079	1211	1306	1485
Aluminium Conductor	In air (A)	463	529	612	710	820	935	1135	1193	1379	1534	1657
	In direct buried (A)	354	399	454	517	585	654	770	801	897	972	1023
	In duct (A)	352	407	464	530	604	680	830	866	986	1082	1213

* Enameled conductor Increasing current capacity approx. 10~13%

110~115kV XLPE Cable with Copper Wire Screen

Cable type : 110~115kV Cu(or AL)/XLPE/CWS/PE (or PVC)



1. Conductor : Copper or enameled copper or aluminum
2. Conductor screen : Semi-conducting compound
3. Insulation : Cross-linked polyethylene
4. Insulation screen : Semi-conducting compound
5. Cushion layer : Semi-conducting tapes
6. Metal screen : Copper wires
7. Water blocking layer : Plastic laminted aluminum foil
8. Outer sheath : Polyethylene or polyvinyl chloride

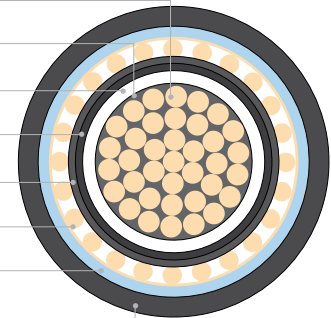

Construction Data

Cross sectional area (mm ²)		240	300	400	500	630	800	1000	1200	1600	2000	2500	
Conductor	Shape	Circular compact stranded						Segmental stranded					
	Diameter (mm)	18.5	20.7	23.3	26.9	30.5	34.3	39.3	42.4	48.9	54.9	61.4	
Thickness of conductor screen Approx. (mm)		1.3	1.3	1.3	1.3	1.3	1.3	1.3	1.3	1.3	1.3	1.3	
Thickness of insulation (mm)		14.0	14.0	14.0	14.0	14.0	14.0	14.0	14.0	14.0	14.0	14.0	
Thickness of insulation screen Approx. (mm)		1.2	1.2	1.2	1.2	1.2	1.2	1.2	1.2	1.2	1.2	1.2	
Dia. x No. of metal screen (mmxEA)		1.2 x 80	1.2 x 80	1.2 x 80	1.2 x 80	1.2 x 80	1.2 x 80	1.2 x 80	1.2 x 80	1.2 x 80	1.2 x 80	1.2 x 80	
Thickness of outer sheath (mm)		4.0	4.0	4.0	4.0	4.0	4.0	4.0	4.0	4.0	4.0	4.0	
Outer diameter of cable (mm)		68.0	70.0	73.0	76.0	80.0	84.0	89.0	92.0	99.0	105.0	111.0	
Weight of cable(Copper conductor) (kg/m)		6.0	6.7	7.7	8.9	10.5	12.4	14.9	16.7	20.9	25.1	30.2	
Weight of cable(Aluminum conductor) (kg/m)		4.5	4.8	5.3	5.8	6.5	7.3	8.3	9.0	10.5	12.1	13.5	
Max. DC Conductor resistance at 20°C (Cu, Ω/km)		0.0754	0.0601	0.047	0.0366	0.0283	0.0221	0.0176	0.0151	0.0113	0.009	0.0072	
Max. DC Conductor resistance at 20°C (AL, Ω/km)		0.125	0.100	0.0778	0.0605	0.0469	0.0367	0.0291	0.0247	0.0186	0.0149	0.0127	
Capacitance (μF/km)		0.17	0.18	0.19	0.21	0.23	0.25	0.28	0.29	0.32	0.36	0.39	

Continuous current rating(Single circuit)

Cross sectional area (mm ²)		240	300	400	500	630	800	1000	1200	1600	2000	2500
Copper Conductor	In air (A)	600	685	789	912	1047	1186	1430	1556	1810	2021	2231
	In direct buried (A)	456	514	582	659	743	825	972	1043	1180	1287	1388
	In duct (A)	455	512	597	678	768	860	1004	1111	1270	1397	1517
Aluminium Conductor	In air (A)	468	535	620	722	838	962	1185	1252	1476	1673	1838
	In direct buried (A)	356	401	458	523	596	671	806	842	967	1071	1151
	In duct (A)	354	399	466	534	609	688	822	882	1017	1132	1218

* Enameled conductor Increasing current capacity approx. 10~13%

110~115kV XLPE Cable with Lead alloy Sheath

Cable type : 110~115kV Cu(or AL)/XLPE/Lead alloy/PE(or PVC)



1. Conductor : Copper or enameled copper or aluminum
2. Conductor screen : Semi-conducting compound
3. Insulation : Cross-linked polyethylene
4. Insulation screen : Semi-conducting compound
5. Cushion layer : Semi-conducting tapes
6. Metal sheath : Lead alloy
7. Outer sheath : Polyethylene or polyvinyl chloride

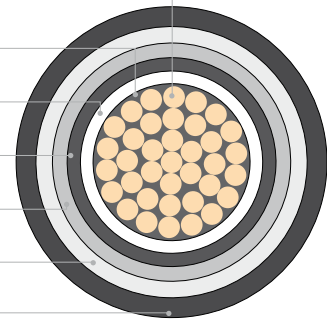

Construction Data

Cross sectional area (mm ²)		240	300	400	500	630	800	1000	1200	1600	2000	2500	
Conductor	Shape	Circular compact stranded						Segmental stranded					
	Diameter (mm)	18.5	20.7	23.3	26.9	30.5	34.3	39.3	42.4	48.9	54.9	61.4	
Thickness of conductor screen Approx. (mm)		1.3	1.3	1.3	1.3	1.3	1.3	1.3	1.3	1.3	1.3	1.3	
Thickness of insulation (mm)		14.0	14.0	14.0	14.0	14.0	14.0	14.0	14.0	14.0	14.0	14.0	
Thickness of insulation screen Approx. (mm)		1.2	1.2	1.2	1.2	1.2	1.2	1.2	1.2	1.2	1.2	1.2	
Thickness of metal sheath (mm)		2.3	2.3	2.4	2.5	2.6	2.7	2.8	3.0	3.2	3.4	3.6	
Thickness of outer sheath (mm)		4.0	4.0	4.0	4.0	4.0	4.0	4.0	4.0	4.0	4.0	4.0	
Outer diameter of cable (mm)		78.0	80.0	83.0	87.0	91.0	95.0	101.0	104.0	111.0	117.0	124.0	
Weight of cable(Copper conductor) (kg/m)		10.6	11.6	13.0	14.8	16.9	19.5	22.9	25.7	31.3	36.9	43.5	
Weight of cable(Aluminum conductor) (kg/m)		9.1	9.7	10.6	11.7	12.9	14.3	16.3	18.0	20.9	23.8	26.8	
Max. DC Conductor resistance at 20°C (Cu, Ω/km)		0.0754	0.0601	0.047	0.0366	0.0283	0.0221	0.0176	0.0151	0.0113	0.009	0.0072	
Max. DC Conductor resistance at 20°C (AL, Ω/km)		0.125	0.100	0.0778	0.0605	0.0469	0.0367	0.0291	0.0247	0.0186	0.0149	0.0127	
Capacitance (μF/km)		0.17	0.18	0.19	0.21	0.23	0.25	0.28	0.29	0.32	0.36	0.39	

Continuous current rating(Single circuit)

Cross sectional area (mm ²)		240	300	400	500	630	800	1000	1200	1600	2000	2500
Copper Conductor	In air (A)	603	689	795	921	1059	1202	1453	1582	1841	2052	2257
	In direct buried (A)	461	519	590	669	756	842	994	1067	1208	1314	1409
	In duct (A)	457	516	600	683	775	868	1015	1093	1283	1411	1529
Aluminium Conductor	In air (A)	469	537	623	727	845	972	1199	1268	1496	1693	1856
	In direct buried (A)	358	404	463	529	604	682	820	858	985	1090	1167
	In duct (A)	355	401	469	537	613	694	830	868	1027	1142	1228

* Enameled conductor Increasing current capacity approx. 10~13%

110~115kV XLPE Cable with Smoothed Aluminum Sheath

Cable type : 110~115kV Cu(or AL)/XLPE/Smoothed AL/PE(or FR-PE)



1. Conductor : Copper or enameled copper or aluminum
2. Conductor screen : Semi-conducting compound
3. Insulation : Cross-linked polyethylene
4. Insulation screen : Semi-conducting compound
5. Cushion layer : Semi-conducting tapes
6. Metal sheath : Smoothed aluminum
7. Outer sheath : Polyethylene or Flame retardant polyethylene

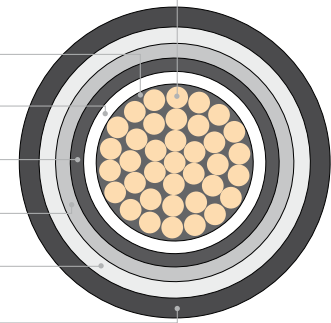

Construction Data

Cross sectional area (mm ²)		240	300	400	500	630	800	1000	1200	1600	2000	2500	
Conductor	Shape	Circular compact stranded						Segmental stranded					
	Diameter (mm)	18.5	20.7	23.3	26.9	30.5	34.3	39.3	42.4	48.9	54.9	61.4	
Thickness of conductor screen Approx. (mm)		1.3	1.3	1.3	1.3	1.3	1.3	1.3	1.3	1.3	1.3	1.3	
Thickness of insulation (mm)		14.0	14.0	14.0	14.0	14.0	14.0	14.0	14.0	14.0	14.0	14.0	
Thickness of insulation screen Approx. (mm)		1.2	1.2	1.2	1.2	1.2	1.2	1.2	1.2	1.2	1.2	1.2	
Thickness of metal sheath (mm)		2.1	2.1	2.0	1.9	1.8	1.7	1.5	1.5	1.4	1.3	1.2	
Thickness of outer sheath (mm)		4.0	4.0	4.0	4.0	4.0	4.0	4.0	4.0	4.0	4.0	4.0	
Outer diameter of cable (mm)		70.0	72.0	75.0	78.0	82.0	85.0	90.0	93.0	100.0	106.0	112.0	
Weight of cable(Copper conductor) (kg/m)		5.9	6.6	7.5	8.8	10.3	12.2	14.6	16.4	20.6	24.7	29.8	
Weight of cable(Aluminum conductor) (kg/m)		4.4	4.7	5.1	5.7	6.3	7.0	8.0	8.7	10.2	11.7	13.1	
Max. DC Conductor resistance at 20°C (Cu, Ω/km)		0.0754	0.0601	0.047	0.0366	0.0283	0.0221	0.0176	0.0151	0.0113	0.009	0.0072	
Max. DC Conductor resistance at 20°C (AL, Ω/km)		0.125	0.100	0.0778	0.0605	0.0469	0.0367	0.0291	0.0247	0.0186	0.0149	0.0127	
Capacitance (μF/km)		0.17	0.18	0.19	0.21	0.23	0.25	0.28	0.29	0.32	0.36	0.39	

Continuous current rating(Single circuit)

Cross sectional area (mm ²)		240	300	400	500	630	800	1000	1200	1600	2000	2500
Copper Conductor	In air (A)	595	678	778	896	1024	1154	1379	1491	1715	1899	2082
	In direct buried (A)	453	509	574	648	726	803	935	995	1111	1201	1285
	In duct (A)	466	525	596	677	766	855	1024	1101	1252	1370	1560
Aluminium Conductor	In air (A)	465	531	614	713	825	943	1154	1215	1421	1598	1748
	In direct buried (A)	355	399	455	518	587	659	784	817	928	1020	1090
	In duct (A)	354	409	467	534	608	687	841	879	1010	1120	1255

* Enameled conductor Increasing current capacity approx. 10~13%

132~138kV XLPE Cable with Corrugated Aluminum Sheath

Cable type : 132~138kV Cu(or AL)/XLPE/Corrugated AL/PE(or PVC)



1. Conductor : Copper or enameled copper or aluminum
2. Conductor screen : Semi-conducting compound
3. Insulation : Cross-linked polyethylene
4. Insulation screen : Semi-conducting compound
5. Cushion layer : Semi-conducting tapes
6. Metal sheath : Corrugated aluminum
7. Outer sheath : Polyethylene or polyvinyl chloride

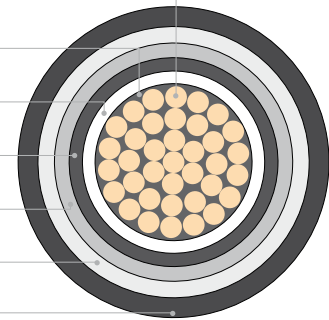

Construction Data

	Cross sectional area (mm ²)	240	300	400	500	630	800	1000	1200	1600	2000	2500	
Conductor	Shape	Circular compact stranded						Segmental stranded					
	Diameter (mm)	18.5	20.7	23.3	26.9	30.5	34.3	39.3	42.4	48.9	54.9	61.4	
Thickness of conductor screen Approx. (mm)		1.5	1.5	1.5	1.5	1.5	1.5	1.5	1.5	1.5	1.5	1.5	
Thickness of insulation (mm)		16.0	16.0	16.0	16.0	16.0	16.0	16.0	16.0	16.0	16.0	16.0	
Thickness of insulation screen Approx. (mm)		1.3	1.3	1.3	1.3	1.3	1.3	1.3	1.3	1.3	1.3	1.3	
Thickness of metal sheath (mm)		1.8	1.9	1.9	2.0	2.1	2.2	2.3	2.3	2.5	2.6	2.7	
Thickness of outer sheath (mm)		4.5	4.5	4.5	4.5	4.5	4.5	4.5	4.5	4.5	4.5	4.5	
Outer diameter of cable (mm)		91.0	93.0	96.0	100.0	104.0	108.0	114.0	117.0	125.0	132.0	139.0	
Weight of cable(Copper conductor) (kg/m)		7.8	8.7	9.7	11.1	12.9	15.1	18.0	19.9	24.6	29.2	34.7	
Weight of cable(Aluminum conductor) (kg/m)		6.3	6.8	7.3	8.0	8.9	9.9	11.3	12.1	14.2	16.2	18.0	
Max. DC Conductor resistance at 20°C (Cu, Ω/km)		0.0754	0.0601	0.047	0.0366	0.0283	0.0221	0.0176	0.0151	0.0113	0.009	0.0072	
Max. DC Conductor resistance at 20°C (AL, Ω/km)		0.125	0.100	0.0778	0.0605	0.0469	0.0367	0.0291	0.0247	0.0186	0.0149	0.0127	
Capacitance (μF/km)		0.15	0.16	0.18	0.19	0.21	0.23	0.25	0.26	0.29	0.32	0.35	

Continuous current rating(Single circuit)

Cross sectional area (mm ²)		240	300	400	500	630	800	1000	1200	1600	2000	2500
Copper Conductor	In air (A)	592	674	773	889	1014	1139	1343	1447	1642	1795	1939
	In direct buried (A)	452	507	572	644	720	792	907	962	1055	1122	1178
	In duct (A)	461	519	589	667	752	861	996	1066	1193	1366	1463
Aluminium Conductor	In air (A)	462	527	609	707	816	931	1128	1185	1371	1526	1650
	In direct buried (A)	353	398	453	515	583	652	767	798	894	969	1022
	In duct (A)	359	404	461	526	615	692	821	856	974	1122	1197

* Enameled conductor Increasing current capacity approx. 10~13%

132~138kV XLPE Cable with Copper Wire Screen

Cable type : 132~138kV Cu(or AL)/XLPE/CWS/PE (or PVC)



1. Conductor : Copper or enameled copper or aluminum
2. Conductor screen : Semi-conducting compound
3. Insulation : Cross-linked polyethylene
4. Insulation screen : Semi-conducting compound
5. Cushion layer : Semi-conducting tapes
6. Metal screen : Copper wires
7. Water blocking layer : Plastic laminted aluminum foil
8. Outer sheath : Polyethylene or polyvinyl chloride

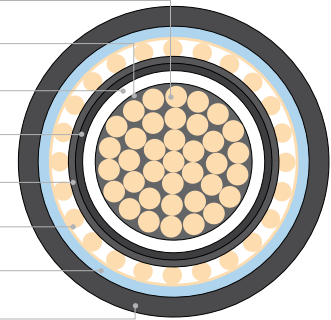

Construction Data

Cross sectional area (mm ²)		240	300	400	500	630	800	1000	1200	1600	2000	2500	
Conductor	Shape	Circular compact stranded						Segmental stranded					
	Diameter (mm)	18.5	20.7	23.3	26.9	30.5	34.3	39.3	42.4	48.9	54.9	61.4	
Thickness of conductor screen Approx. (mm)		1.5	1.5	1.5	1.5	1.5	1.5	1.5	1.5	1.5	1.5	1.5	
Thickness of insulation (mm)		16.0	16.0	16.0	16.0	16.0	16.0	16.0	16.0	16.0	16.0	16.0	
Thickness of insulation screen Approx. (mm)		1.3	1.3	1.3	1.3	1.3	1.3	1.3	1.3	1.3	1.3	1.3	
Dia. x No. of metal screen (mmxEA)		1.2x 80	1.2 x 80	1.2 x 80	1.2 x 80	1.2 x 80	1.2 x 80	1.2 x 80	1.2 x 80	1.2 x 80	1.2 x 80	1.2 x 80	
Thickness of outer sheath (mm)		4.5	4.5	4.5	4.5	4.5	4.5	4.5	4.5	4.5	4.5	4.5	
Outer diameter of cable (mm)		74.0	76.0	78.0	82.0	86.0	90.0	95.0	98.0	105.0	111.0	117.0	
Weight of cable(Copper conductor) (kg/m)		6.6	7.4	8.4	9.6	11.2	13.2	15.7	17.5	21.8	26.0	31.2	
Weight of cable(Aluminum conductor) (kg/m)		5.1	5.5	6.0	6.5	7.2	8.0	9.1	9.8	11.4	13.0	14.5	
Max. DC Conductor resistance at 20°C (Cu, Ω/km)		0.0754	0.0601	0.047	0.0366	0.0283	0.0221	0.0176	0.0151	0.0113	0.009	0.0072	
Max. DC Conductor resistance at 20°C (AL, Ω/km)		0.125	0.100	0.0778	0.0605	0.0469	0.0367	0.0291	0.0247	0.0186	0.0149	0.0127	
Capacitance (μF/km)		0.15	0.16	0.18	0.19	0.21	0.23	0.25	0.26	0.29	0.32	0.35	

Continuous current rating(Single circuit)

Cross sectional area (mm ²)		240	300	400	500	630	800	1000	1200	1600	2000	2500
Copper Conductor	In air (A)	599	684	787	910	1045	1183	1424	1550	1803	2014	2225
	In direct buried (A)	456	514	583	661	745	829	974	1046	1185	1294	1397
	In duct (A)	464	523	595	676	765	878	1026	1106	1264	1390	1509
Aluminium Conductor	In air (A)	467	533	618	720	835	958	1179	1245	1468	1664	1828
	In direct buried (A)	356	401	458	524	597	673	807	844	970	1075	1156
	In duct (A)	361	407	465	532	607	686	839	878	1013	1127	1260

* Enameled conductor Increasing current capacity approx. 10~13%

132~138kV XLPE Cable with Lead alloy Sheath

Cable type : 132~138kV Cu(or AL)/XLPE/Lead alloy/PE(or PVC)



1. Conductor : Copper or enameled copper or aluminum
2. Conductor screen : Semi-conducting compound
3. Insulation : Cross-linked polyethylene
4. Insulation screen : Semi-conducting compound
5. Cushion layer : Semi-conducting tapes
6. Metal sheath : Lead alloy
7. Outer sheath : Polyethylene or polyvinyl chloride

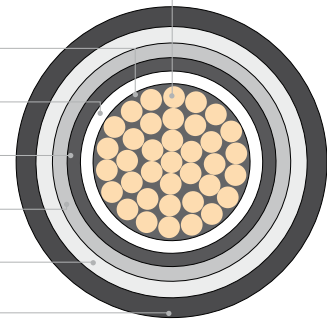

Construction Data

	Cross sectional area (mm ²)	240	300	400	500	630	800	1000	1200	1600	2000	2500	
Conductor	Shape	Circular compact stranded						Segmental stranded					
	Diameter (mm)	18.5	20.7	23.3	26.9	30.5	34.3	39.3	42.4	48.9	54.9	61.4	
	Thickness of conductor screen Approx. (mm)	1.5	1.5	1.5	1.5	1.5	1.5	1.5	1.5	1.5	1.5	1.5	
	Thickness of insulation (mm)	16.0	16.0	16.0	16.0	16.0	16.0	16.0	16.0	16.0	16.0	16.0	
	Thickness of insulation screen Approx. (mm)	1.3	1.3	1.3	1.3	1.3	1.3	1.3	1.3	1.3	1.3	1.3	
	Thickness of metal sheath (mm)	2.4	2.4	2.5	2.6	2.7	2.8	2.9	3.1	3.3	3.5	3.7	
	Thickness of outer sheath (mm)	4.5	4.5	4.5	4.5	4.5	4.5	4.5	4.5	4.5	4.5	4.5	
	Outer diameter of cable (mm)	84.0	86.0	89.0	93.0	97.0	101.0	106.0	110.0	117.0	123.0	130.0	
	Weight of cable(Copper conductor) (kg/m)	11.9	13.0	14.4	16.3	18.5	21.1	24.6	27.5	33.2	38.9	45.7	
	Weight of cable(Aluminum conductor) (kg/m)	10.4	11.1	12.0	13.2	14.4	15.9	18.0	19.8	22.8	25.8	29.0	
	Max. DC Conductor resistance at 20°C (Cu, Ω/km)	0.0754	0.0601	0.047	0.0366	0.0283	0.0221	0.0176	0.0151	0.0113	0.009	0.0072	
	Max. DC Conductor resistance at 20°C (AL, Ω/km)	0.125	0.100	0.0778	0.0605	0.0469	0.0367	0.0291	0.0247	0.0186	0.0149	0.0127	
	Capacitance (μF/km)	0.15	0.16	0.18	0.19	0.21	0.23	0.25	0.26	0.29	0.32	0.35	

Continuous current rating(Single circuit)

	Cross sectional area (mm ²)	240	300	400	500	630	800	1000	1200	1600	2000	2500
Copper Conductor	In air (A)	602	688	793	918	1056	1198	1443	1571	1828	2037	2241
	In direct buried (A)	460	518	589	669	755	842	992	1064	1204	1310	1405
	In duct (A)	465	525	597	679	769	861	1032	1112	1271	1395	1581
Aluminium Conductor	In air (A)	468	535	621	725	841	967	1191	1258	1484	1679	1840
	In direct buried (A)	358	404	462	529	603	681	818	855	982	1086	1163
	In duct (A)	362	408	466	534	609	689	843	882	1018	1131	1263

* Enameled conductor Increasing current capacity approx. 10~13%

132~138kV XLPE Cable with Smoothed Aluminum Sheath

Cable type : 132~138kV Cu(or AL)/XLPE/Smoothed AL/PE(or FR-PE)



1. Conductor : Copper or enameled copper or aluminum
2. Conductor screen : Semi-conducting compound
3. Insulation : Cross-linked polyethylene
4. Insulation screen : Semi-conducting compound
5. Cushion layer : Semi-conducting tapes
6. Metal sheath : Smoothed aluminum
7. Outer sheath : Polyethylene or Flame retardant polyethylene

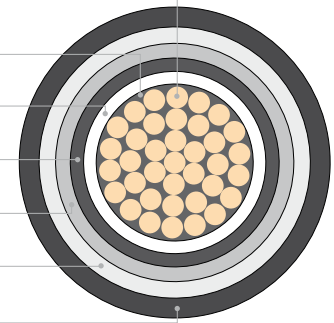

Construction Data

		240	300	400	500	630	800	1000	1200	1600	2000	2500
Conductor	Cross sectional area (mm ²)											
	Shape	Circular compact stranded						Segmental stranded				
	Diameter (mm)	18.5	20.7	23.3	26.9	30.5	34.3	39.3	42.4	48.9	54.9	61.4
	Thickness of conductor screen Approx. (mm)	1.5	1.5	1.5	1.5	1.5	1.5	1.5	1.5	1.5	1.5	1.5
	Thickness of insulation (mm)	16.0	16.0	16.0	16.0	16.0	16.0	16.0	16.0	16.0	16.0	16.0
	Thickness of insulation screen Approx. (mm)	1.3	1.3	1.3	1.3	1.3	1.3	1.3	1.3	1.3	1.3	1.3
	Thickness of metal sheath (mm)	2.0	1.9	1.8	1.7	1.6	1.6	1.5	1.4	1.3	1.2	1.1
	Thickness of outer sheath (mm)	4.5	4.5	4.5	4.5	4.5	4.5	4.5	4.5	4.5	4.5	4.5
	Outer diameter of cable (mm)	76.0	78.0	80.0	83.0	87.0	91.0	96.0	99.0	105.0	111.0	117.0
	Weight of cable(Copper conductor) (kg/m)	6.5	7.2	8.1	9.3	10.9	12.9	15.4	17.2	21.3	25.5	30.6
	Weight of cable(Aluminum conductor) (kg/m)	5.0	5.3	5.7	6.2	6.9	7.7	8.7	9.4	11.0	12.5	13.9
	Max. DC Conductor resistance at 20°C (Cu, Ω/km)	0.0754	0.0601	0.047	0.0366	0.0283	0.0221	0.0176	0.0151	0.0113	0.009	0.0072
	Max. DC Conductor resistance at 20°C (AL, Ω/km)	0.125	0.100	0.0778	0.0605	0.0469	0.0367	0.0291	0.0247	0.0186	0.0149	0.0127
	Capacitance (μF/km)	0.15	0.16	0.18	0.19	0.21	0.23	0.25	0.26	0.29	0.32	0.35

Continuous current rating(Single circuit)

Cross sectional area (mm ²)		240	300	400	500	630	800	1000	1200	1600	2000	2500
Copper Conductor	In air (A)	594	676	776	894	1023	1152	1374	1490	1717	1893	2076
	In direct buried (A)	452	508	574	647	726	802	932	997	1116	1198	1283
	In duct (A)	463	522	592	673	760	872	1015	1092	1241	1420	1542
Aluminium Conductor	In air (A)	464	529	612	711	822	940	1148	1211	1418	1591	1739
	In direct buried (A)	354	398	454	517	587	658	782	817	931	1018	1089
	In duct (A)	360	406	464	530	620	699	833	871	1001	1153	1242

* Enameled conductor Increasing current capacity approx. 10~13%

150~161kV XLPE Cable with Corrugated Aluminum Sheath

Cable type : 150~161kV Cu(or AL)/XLPE/Corrugated AL/PE(or PVC)



1. Conductor : Copper or enameled copper or aluminum
2. Conductor screen : Semi-conducting compound
3. Insulation : Cross-linked polyethylene
4. Insulation screen : Semi-conducting compound
5. Cushion layer : Semi-conducting tapes
6. Metal sheath : Corrugated aluminum
7. Outer sheath : Polyethylene or polyvinyl chloride

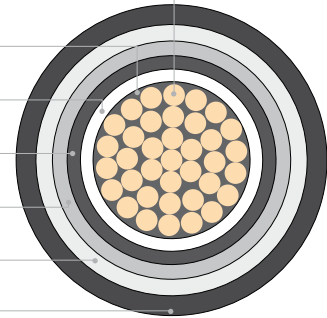

Construction Data

Cross sectional area (mm ²)		240	300	400	500	630	800	1000	1200	1600	2000	2500	
Conductor	Shape	Circular compact stranded						Segmental stranded					
	Diameter (mm)	18.5	20.7	23.3	26.9	30.5	34.3	39.3	42.4	48.9	54.9	61.4	
Thickness of conductor screen Approx. (mm)		1.5	1.5	1.5	1.5	1.5	1.5	1.5	1.5	1.5	1.5	1.5	
Thickness of insulation (mm)		17.0	17.0	17.0	17.0	17.0	17.0	17.0	17.0	17.0	17.0	17.0	
Thickness of insulation screen Approx. (mm)		1.3	1.3	1.3	1.3	1.3	1.3	1.3	1.3	1.3	1.3	1.3	
Thickness of metal sheath (mm)		1.9	1.9	2.0	2.0	2.1	2.2	2.3	2.4	2.5	2.6	2.7	
Thickness of outer sheath (mm)		4.5	4.5	4.5	4.5	4.5	4.5	4.5	4.5	4.5	4.5	4.5	
Outer diameter of cable (mm)		93.0	95.0	98.0	102.0	106.0	110.0	116.0	120.0	127.0	134.0	141.0	
Weight of cable(Copper conductor) (kg/m)		8.1	8.9	10.0	11.4	13.2	15.4	18.3	20.3	24.9	29.6	35.1	
Weight of cable(Aluminum conductor) (kg/m)		6.6	7.0	7.6	8.3	9.2	10.2	11.6	12.6	14.6	16.5	18.4	
Max. DC Conductor resistance at 20°C (Cu, Ω/km)		0.0754	0.0601	0.047	0.0366	0.0283	0.0221	0.0176	0.0151	0.0113	0.009	0.0072	
Max. DC Conductor resistance at 20°C (AL, Ω/km)		0.125	0.100	0.0778	0.0605	0.0469	0.0367	0.0291	0.0247	0.0186	0.0149	0.0127	
Capacitance (μF/km)		0.15	0.16	0.17	0.18	0.20	0.22	0.24	0.25	0.28	0.30	0.33	

Continuous current rating(Single circuit)

Cross sectional area (mm ²)		240	300	400	500	630	800	1000	1200	1600	2000	2500
Copper Conductor	In air (A)	591	672	771	887	1011	1136	1339	1440	1637	1791	1935
	In direct buried (A)	451	506	571	643	718	790	904	956	1052	1118	1175
	In duct (A)	460	517	586	681	769	857	991	1058	1249	1358	1453
Aluminium Conductor	In air (A)	461	526	608	705	814	928	1124	1180	1366	1521	1645
	In direct buried (A)	353	397	452	514	582	651	765	794	892	967	1019
	In duct (A)	358	403	460	525	611	689	817	851	1012	1116	1190

* Enameled conductor Increasing current capacity approx. 10~13%

150~161kV XLPE Cable with Copper Wire Screen

Cable type : 150~161kV Cu(or AL)/XLPE/CWS/PE (or PVC)



1. Conductor : Copper or enameled copper or aluminum
2. Conductor screen : Semi-conducting compound
3. Insulation : Cross-linked polyethylene
4. Insulation screen : Semi-conducting compound
5. Cushion layer : Semi-conducting tapes
6. Metal screen : Copper wires
7. Water blocking layer : Plastic laminted aluminum foil
8. Outer sheath : Polyethylene or polyvinyl chloride

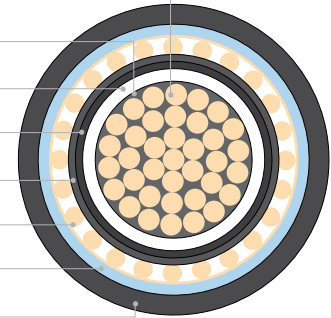

Construction Data

	Cross sectional area (mm ²)	240	300	400	500	630	800	1000	1200	1600	2000	2500	
Conductor	Shape	Circular compact stranded						Segmental stranded					
	Diameter (mm)	18.5	20.7	23.3	26.9	30.5	34.3	39.3	42.4	48.9	54.9	61.4	
Thickness of conductor screen Approx. (mm)		1.5	1.5	1.5	1.5	1.5	1.5	1.5	1.5	1.5	1.5	1.5	
Thickness of insulation (mm)		17.0	17.0	17.0	17.0	17.0	17.0	17.0	17.0	17.0	17.0	17.0	
Thickness of insulation screen Approx. (mm)		1.3	1.3	1.3	1.3	1.3	1.3	1.3	1.3	1.3	1.3	1.3	
Dia. x No. of metal screen (mm×EA)		1.2×80	1.2×80	1.2×80	1.2×80	1.2×80	1.2×80	1.2×80	1.2×80	1.2×80	1.2×80	1.2×80	
Thickness of outer sheath (mm)		4.5	4.5	4.5	4.5	4.5	4.5	4.5	4.5	4.5	4.5	4.5	
Outer diameter of cable (mm)		76.0	78.0	80.0	84.0	88.0	92.0	97.0	100.0	107.0	113.0	119.0	
Weight of cable(Copper conductor) (kg/m)		6.9	7.6	8.6	9.9	11.5	13.5	16.0	17.8	22.1	26.4	31.5	
Weight of cable(Aluminum conductor) (kg/m)		5.4	5.7	6.2	6.8	7.4	8.3	9.4	10.1	11.8	13.3	14.8	
Max. DC Conductor resistance at 20°C (Cu, Ω/km)		0.0754	0.0601	0.047	0.0366	0.0283	0.0221	0.0176	0.0151	0.0113	0.009	0.0072	
Max. DC Conductor resistance at 20°C (AL, Ω/km)		0.125	0.100	0.0778	0.0605	0.0469	0.0367	0.0291	0.0247	0.0186	0.0149	0.0127	
Capacitance (μF/km)		0.15	0.16	0.17	0.18	0.20	0.22	0.24	0.25	0.28	0.30	0.33	

Continuous current rating(Single circuit)

Cross sectional area (mm ²)		240	300	400	500	630	800	1000	1200	1600	2000	2500
Copper Conductor	In air (A)	598	683	786	908	1043	1182	1422	1547	1800	2012	2223
	In direct buried (A)	457	514	583	661	746	830	975	1047	1186	1296	1400
	In duct (A)	453	510	594	675	764	855	1025	1104	1262	1387	1576
Aluminium Conductor	In air (A)	466	532	617	719	833	957	1177	1243	1465	1660	1824
	In direct buried (A)	356	401	459	524	597	674	808	845	971	1077	1158
	In duct (A)	352	397	464	531	606	685	838	877	1012	1125	1258

* Enameled conductor Increasing current capacity approx. 10~13%

150~161kV XLPE Cable with Lead alloy Sheath

Cable type : 150~161kV Cu(or AL)/XLPE/Lead alloy/PE(or PVC)



1. Conductor : Copper or enameled copper or aluminum
2. Conductor screen : Semi-conducting compound
3. Insulation : Cross-linked polyethylene
4. Insulation screen : Semi-conducting compound
5. Cushion layer : Semi-conducting tapes
6. Metal sheath : Lead alloy
7. Outer sheath : Polyethylene or polyvinyl chloride

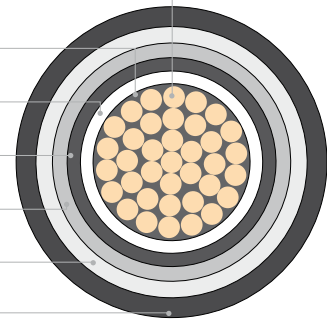

Construction Data

Cross sectional area (mm ²)		240	300	400	500	630	800	1000	1200	1600	2000	2500	
Conductor	Shape	Circular compact stranded						Segmental stranded					
	Diameter (mm)	18.5	20.7	23.3	26.9	30.5	34.3	39.3	42.4	48.9	54.9	61.4	
Thickness of conductor screen Approx. (mm)		1.5	1.5	1.5	1.5	1.5	1.5	1.5	1.5	1.5	1.5	1.5	
Thickness of insulation (mm)		17.0	17.0	17.0	17.0	17.0	17.0	17.0	17.0	17.0	17.0	17.0	
Thickness of insulation screen Approx. (mm)		1.3	1.3	1.3	1.3	1.3	1.3	1.3	1.3	1.3	1.3	1.3	
Thickness of metal sheath (mm)		2.4	2.5	2.6	2.7	2.8	2.9	3.0	3.2	3.4	3.6	3.8	
Thickness of outer sheath (mm)		4.5	4.5	4.5	4.5	4.5	4.5	4.5	4.5	4.5	4.5	4.5	
Outer diameter of cable (mm)		86.0	88.0	91.0	95.0	99.0	103.0	109.0	112.0	119.0	125.0	132.0	
Weight of cable(Copper conductor) (kg/m)		12.5	13.6	15.0	16.9	19.1	21.8	25.3	28.2	34.0	39.7	46.5	
Weight of cable(Aluminum conductor) (kg/m)		11.0	11.7	12.6	13.8	15.1	16.6	18.7	20.5	23.6	26.7	29.8	
Max. DC Conductor resistance at 20°C (Cu, Ω/km)		0.0754	0.0601	0.047	0.0366	0.0283	0.0221	0.0176	0.0151	0.0113	0.009	0.0072	
Max. DC Conductor resistance at 20°C (AL, Ω/km)		0.125	0.100	0.0778	0.0605	0.0469	0.0367	0.0291	0.0247	0.0186	0.0149	0.0127	
Capacitance (μF/km)		0.15	0.16	0.17	0.18	0.20	0.22	0.24	0.25	0.28	0.30	0.33	

Continuous current rating(Single circuit)

Cross sectional area (mm ²)		240	300	400	500	630	800	1000	1200	1600	2000	2500
Copper Conductor	In air (A)	601	686	791	916	1053	1195	1438	1565	1820	2029	2231
	In direct buried (A)	459	518	588	668	754	841	989	1061	1200	1305	1399
	In duct (A)	464	523	595	677	767	858	1028	1108	1264	1387	1572
Aluminium Conductor	In air (A)	467	534	620	723	839	965	1187	1254	1478	1672	1832
	In direct buried (A)	357	403	461	528	602	680	816	853	979	1083	1159
	In duct (A)	361	407	465	532	607	687	840	879	1013	1126	1257

* Enameled conductor Increasing current capacity approx. 10~13%

150~161kV XLPE Cable with Smoothed Aluminum Sheath

Cable type : 150~161kV Cu(or AL)/XLPE/Smoothed AL/PE(or FR-PE)



1. Conductor : Copper or enameled copper or aluminum
2. Conductor screen : Semi-conducting compound
3. Insulation : Cross-linked polyethylene
4. Insulation screen : Semi-conducting compound
5. Cushion layer : Semi-conducting tapes
6. Metal sheath : Smoothed aluminum
7. Outer sheath : Polyethylene or Flame retardant polyethylene

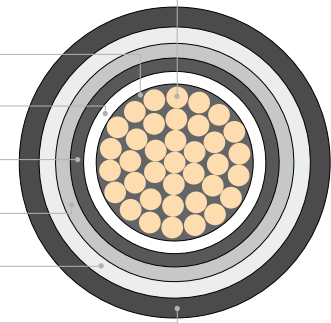

Construction Data

Cross sectional area (mm ²)		240	300	400	500	630	800	1000	1200	1600	2000	2500	
Conductor	Shape	Circular compact stranded						Segmental stranded					
	Diameter (mm)	18.5	20.7	23.3	26.9	30.5	34.3	39.3	42.4	48.9	54.9	61.4	
Thickness of conductor screen Approx. (mm)		1.5	1.5	1.5	1.5	1.5	1.5	1.5	1.5	1.5	1.5	1.5	
Thickness of insulation (mm)		17.0	17.0	17.0	17.0	17.0	17.0	17.0	17.0	17.0	17.0	17.0	
Thickness of insulation screen Approx. (mm)		1.3	1.3	1.3	1.3	1.3	1.3	1.3	1.3	1.3	1.3	1.3	
Thickness of metal sheath (mm)		1.9	1.8	1.8	1.7	1.6	1.5	1.4	1.4	1.3	1.2	1.1	
Thickness of outer sheath (mm)		4.5	4.5	4.5	4.5	4.5	4.5	4.5	4.5	4.5	4.5	4.5	
Outer diameter of cable (mm)		77.0	79.0	82.0	85.0	89.0	92.0	98.0	101.0	107.0	113.0	119.0	
Weight of cable(Copper conductor) (kg/m)		6.6	7.3	8.3	9.6	11.1	13.1	15.6	17.5	21.7	25.9	31.0	
Weight of cable(Aluminum conductor) (kg/m)		5.1	5.4	5.9	6.5	7.1	7.9	9.0	9.7	11.3	12.9	14.3	
Max. DC Conductor resistance at 20°C (Cu, Ω/km)		0.0754	0.0601	0.047	0.0366	0.0283	0.0221	0.0176	0.0151	0.0113	0.009	0.0072	
Max. DC Conductor resistance at 20°C (AL, Ω/km)		0.125	0.100	0.0778	0.0605	0.0469	0.0367	0.0291	0.0247	0.0186	0.0149	0.0127	
Capacitance (μF/km)		0.15	0.16	0.17	0.18	0.20	0.22	0.24	0.25	0.28	0.30	0.33	

Continuous current rating(Single circuit)

Cross sectional area (mm ²)		240	300	400	500	630	800	1000	1200	1600	2000	2500
Copper Conductor	In air (A)	593	675	775	892	1020	1151	1373	1485	1711	1887	2070
	In direct buried (A)	452	507	573	646	725	802	933	993	1112	1194	1279
	In duct (A)	462	520	581	686	777	869	1012	1087	1287	1412	1533
Aluminium Conductor	In air (A)	463	528	611	709	820	938	1147	1207	1413	1592	1733
	In direct buried (A)	354	398	453	516	586	658	783	815	928	1022	1085
	In duct (A)	359	405	462	528	616	696	831	868	1033	1150	1235

* Enameled conductor Increasing current capacity approx. 10~13%

220~230kV XLPE Cable with Corrugated Aluminum Sheath

Cable type : 220~230kV Cu(or AL)/XLPE/Corrugated AL/PE(or PVC)



1. Conductor : Copper or enameled copper or aluminum
2. Conductor screen : Semi-conducting compound
3. Insulation : Cross-linked polyethylene
4. Insulation screen : Semi-conducting compound
5. Cushion layer : Semi-conducting tapes
6. Metal sheath : Corrugated aluminum
7. Outer sheath : Polyethylene or polyvinyl chloride

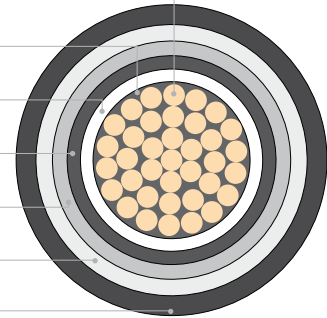

Construction Data

		240	300	400	500	630	800	1000	1200	1600	2000	2500
Conductor	Cross sectional area (mm ²)											
	Shape	Circular compact stranded						Segmental stranded				
	Diameter (mm)	18.5	20.7	23.3	26.9	30.5	34.3	39.3	42.4	48.9	54.9	61.4
	Thickness of conductor screen Approx. (mm)	2.0	2.0	2.0	2.0	2.0	2.0	2.0	2.0	2.0	2.0	2.0
	Thickness of insulation (mm)	21.0	21.0	21.0	21.0	21.0	21.0	21.0	21.0	21.0	21.0	21.0
	Thickness of insulation screen Approx. (mm)	1.5	1.5	1.5	1.5	1.5	1.5	1.5	1.5	1.5	1.5	1.5
	Thickness of metal sheath (mm)	2.0	2.1	2.1	2.2	2.3	2.4	2.5	2.5	2.7	2.8	2.9
	Thickness of outer sheath (mm)	5.0	5.0	5.0	5.0	5.0	5.0	5.0	5.0	5.0	5.0	5.0
	Outer diameter of cable (mm)	103.0	105.0	108.0	112.0	116.0	121.0	127.0	130.0	138.0	144.0	151.0
	Weight of cable(Copper conductor) (kg/m)	9.6	10.6	11.6	13.2	15.1	17.4	20.3	22.3	27.2	31.9	37.6
	Weight of cable(Aluminum conductor) (kg/m)	8.1	8.7	9.2	10.1	11.1	12.2	13.7	14.6	16.8	18.9	20.9
	Max. DC Conductor resistance at 20°C (Cu, Ω/km)	0.0754	0.0601	0.047	0.0366	0.0283	0.0221	0.0176	0.0151	0.0113	0.009	0.0072
	Max. DC Conductor resistance at 20°C (AL, Ω/km)	0.125	0.100	0.0778	0.0605	0.0469	0.0367	0.0291	0.0247	0.0186	0.0149	0.0127
	Capacitance (μF/km)	0.13	0.14	0.15	0.16	0.17	0.19	0.20	0.22	0.24	0.26	0.28

Continuous current rating(Single circuit)

		240	300	400	500	630	800	1000	1200	1600	2000	2500
Copper Conductor	In air (A)	584	664	761	874	996	1119	1315	1417	1612	1766	1913
	In direct buried (A)	447	501	564	635	709	780	889	942	1035	1102	1160
	In duct (A)	462	520	589	667	752	836	1004	1077	1211	1363	1464
Aluminium Conductor	In air (A)	456	520	600	695	801	914	1104	1160	1343	1497	1621
	In direct buried (A)	350	394	448	509	575	643	754	784	879	953	1006
	In duct (A)	359	405	462	527	599	674	827	864	985	1119	1195

* Enameled conductor Increasing current capacity approx. 10~13%

220~230kV XLPE Cable with Copper Wire Screen

Cable type : 220~230kV Cu(or AL)/XLPE/CWS/PE (or PVC)



1. Conductor : Copper or enameled copper or aluminum
2. Conductor screen : Semi-conducting compound
3. Insulation : Cross-linked polyethylene
4. Insulation screen : Semi-conducting compound
5. Cushion layer : Semi-conducting tapes
6. Metal screen : Copper wires
7. Water blocking layer : Plastic laminted aluminum foil
8. Outer sheath : Polyethylene or polyvinyl chloride

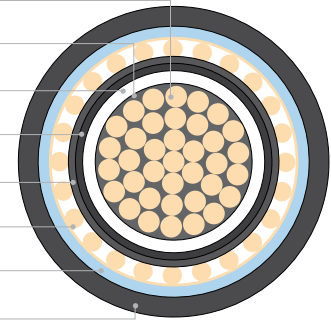

Construction Data

Cross sectional area (mm ²)		240	300	400	500	630	800	1000	1200	1600	2000	2500
Conductor	Shape	Circular compact stranded						Segmental stranded				
	Diameter (mm)	18.5	20.7	23.3	26.9	30.5	34.3	39.3	42.4	48.9	54.9	61.4
Thickness of conductor screen Approx. (mm)		2.0	2.0	2.0	2.0	2.0	2.0	2.0	2.0	2.0	2.0	2.0
Thickness of insulation (mm)		21.0	21.0	21.0	21.0	21.0	21.0	21.0	21.0	21.0	21.0	21.0
Thickness of insulation screen Approx. (mm)		1.5	1.5	1.5	1.5	1.5	1.5	1.5	1.5	1.5	1.5	1.5
Dia. x No. of metal screen (mmxEA)		1.2 x 80	1.2 x 80	1.2 x 80	1.2 x 80	1.2 x 80	1.2 x 80	1.2 x 80	1.2 x 80	1.2 x 80	1.2 x 80	1.2 x 80
Thickness of outer sheath (mm)		5.0	5.0	5.0	5.0	5.0	5.0	5.0	5.0	5.0	5.0	5.0
Outer diameter of cable (mm)		85.0	87.0	90.0	93.0	97.0	101.0	106.0	109.0	116.0	122.0	128.0
Weight of cable(Copper conductor) (kg/m)		8.0	8.8	9.9	11.1	12.8	14.9	17.5	19.3	23.7	28.1	33.3
Weight of cable(Aluminum conductor) (kg/m)		6.5	6.9	7.5	8.0	8.8	9.7	10.8	11.6	13.4	15.0	16.6
Max. DC Conductor resistance at 20°C (Cu, Ω/km)		0.0754	0.0601	0.047	0.0366	0.0283	0.0221	0.0176	0.0151	0.0113	0.009	0.0072
Max. DC Conductor resistance at 20°C (AL, Ω/km)		0.125	0.100	0.0778	0.0605	0.0469	0.0367	0.0291	0.0247	0.0186	0.0149	0.0127
Capacitance (μF/km)		0.13	0.14	0.15	0.16	0.17	0.19	0.20	0.22	0.24	0.26	0.28

Continuous current rating(Single circuit)

Cross sectional area (mm ²)		240	300	400	500	630	800	1000	1200	1600	2000	2500
Copper Conductor	In air (A)	595	679	781	903	1037	1176	1410	1534	1787	1998	2210
	In direct buried (A)	457	515	584	663	749	834	978	1051	1193	1305	1413
	In duct (A)	461	520	590	671	777	871	1017	1095	1251	1431	1562
Aluminium Conductor	In air (A)	463	529	613	713	827	950	1165	1230	1450	1644	1807
	In direct buried (A)	357	402	459	525	599	676	810	847	975	1082	1165
	In duct (A)	358	404	462	528	615	696	832	871	1004	1157	1249

* Enameled conductor Increasing current capacity approx. 10~13%

220~230kV XLPE Cable with Lead alloy Sheath

Cable type : 220~230kV Cu(or AL)/XLPE/Lead alloy/PE(or PVC)



1. Conductor : Copper or enameled copper or aluminum
2. Conductor screen : Semi-conducting compound
3. Insulation : Cross-linked polyethylene
4. Insulation screen : Semi-conducting compound
5. Cushion layer : Semi-conducting tapes
6. Metal sheath : Lead alloy
7. Outer sheath : Polyethylene or polyvinyl chloride

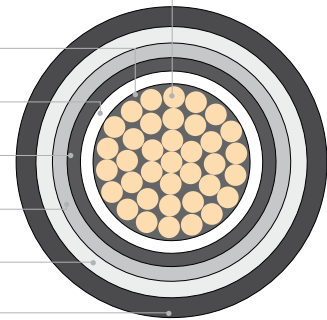

Construction Data

	Cross sectional area (mm ²)	240	300	400	500	630	800	1000	1200	1600	2000	2500	
Conductor	Shape	Circular compact stranded						Segmental stranded					
	Diameter (mm)	18.5	20.7	23.3	26.9	30.5	34.3	39.3	42.4	48.9	54.9	61.4	
Thickness of conductor screen Approx.	(mm)	2.0	2.0	2.0	2.0	2.0	2.0	2.0	2.0	2.0	2.0	2.0	
Thickness of insulation	(mm)	21.0	21.0	21.0	21.0	21.0	21.0	21.0	21.0	21.0	21.0	21.0	
Thickness of insulation screen Approx.	(mm)	1.5	1.5	1.5	1.5	1.5	1.5	1.5	1.5	1.5	1.5	1.5	
Thickness of metal sheath	(mm)	2.7	2.7	2.8	2.9	3.0	3.1	3.2	3.4	3.6	3.8	4.0	
Thickness of outer sheath	(mm)	5.0	5.0	5.0	5.0	5.0	5.0	5.0	5.0	5.0	5.0	5.0	
Outer diameter of cable	(mm)	96.0	98.0	101.0	105.0	109.0	113.0	118.0	122.0	129.0	135.0	142.0	
Weight of cable(Copper conductor)	(kg/m)	15.1	16.2	17.8	19.7	22.1	24.9	28.6	31.6	37.6	43.5	50.6	
Weight of cable(Aluminum conductor)	(kg/m)	13.6	14.3	15.4	16.6	18.1	19.7	22.0	23.9	27.2	30.5	33.9	
Max. DC Conductor resistance at 20°C	(Cu, Ω/km)	0.0754	0.0601	0.047	0.0366	0.0283	0.0221	0.0176	0.0151	0.0113	0.009	0.0072	
Max. DC Conductor resistance at 20°C	(AL, Ω/km)	0.125	0.100	0.0778	0.0605	0.0469	0.0367	0.0291	0.0247	0.0186	0.0149	0.0127	
Capacitance	(μF/km)	0.13	0.14	0.15	0.16	0.17	0.19	0.20	0.22	0.24	0.26	0.28	

Continuous current rating(Single circuit)

	Cross sectional area (mm ²)	240	300	400	500	630	800	1000	1200	1600	2000	2500
Copper Conductor	In air (A)	595	679	782	904	1039	1179	1413	1537	1786	1989	2187
	In direct buried (A)	456	514	584	663	749	835	978	1048	1184	1287	1379
	In duct (A)	458	516	586	680	771	863	1008	1084	1281	1409	1529
Aluminium Conductor	In air (A)	463	528	612	713	827	950	1166	1230	1448	1637	1792
	In direct buried (A)	355	401	458	524	597	674	807	843	967	1068	1142
	In duct (A)	356	401	458	535	610	690	825	862	1025	1140	1226

* Enameled conductor Increasing current capacity approx. 10~13%

220~230kV XLPE Cable with Smoothed Aluminum Sheath

Cable type : 220~230kV Cu(or AL)/XLPE/Smoothed AL/PE(or FR-PE)



1. Conductor : Copper or enameled copper or aluminum
2. Conductor screen : Semi-conducting compound
3. Insulation : Cross-linked polyethylene
4. Insulation screen : Semi-conducting compound
5. Cushion layer : Semi-conducting tapes
6. Metal sheath : Smooth aluminum
7. Outer sheath : Polyethylene or Flame retardant polyethylene

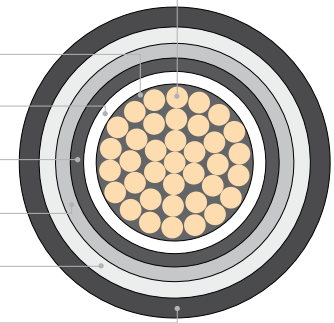

Construction Data

		240	300	400	500	630	800	1000	1200	1600	2000	2500
Conductor	Cross sectional area (mm ²)											
	Shape	Circular compact stranded						Segmental stranded				
	Diameter (mm)	18.5	20.7	23.3	26.9	30.5	34.3	39.3	42.4	48.9	54.9	61.4
	Thickness of conductor screen Approx. (mm)	2.0	2.0	2.0	2.0	2.0	2.0	2.0	2.0	2.0	2.0	2.0
	Thickness of insulation (mm)	21.0	21.0	21.0	21.0	21.0	21.0	21.0	21.0	21.0	21.0	21.0
	Thickness of insulation screen Approx. (mm)	1.5	1.5	1.5	1.5	1.5	1.5	1.5	1.5	1.5	1.5	1.5
	Thickness of metal sheath (mm)	2.7	2.6	2.5	2.4	2.3	2.2	2.1	2.0	1.9	1.8	1.7
	Thickness of outer sheath (mm)	5.0	5.0	5.0	5.0	5.0	5.0	5.0	5.0	5.0	5.0	5.0
	Outer diameter of cable (mm)	88.0	90.0	93.0	96.0	100.0	103.0	109.0	111.0	118.0	124.0	130.0
	Weight of cable(Copper conductor) (kg/m)	8.4	9.1	10.1	11.4	13.0	15.0	17.6	19.5	23.8	28.1	33.3
	Weight of cable(Aluminum conductor) (kg/m)	6.9	7.2	7.7	8.3	9.0	9.8	11.0	11.7	13.4	15.1	16.6
	Max. DC Conductor resistance at 20°C (Cu, Ω/km)	0.0754	0.0601	0.047	0.0366	0.0283	0.0221	0.0176	0.0151	0.0113	0.009	0.0072
	Max. DC Conductor resistance at 20°C (AL, Ω/km)	0.125	0.100	0.0778	0.0605	0.0469	0.0367	0.0291	0.0247	0.0186	0.0149	0.0127
	Capacitance (μF/km)	0.13	0.14	0.15	0.16	0.17	0.19	0.20	0.22	0.24	0.26	0.28

Continuous current rating(Single circuit)

		240	300	400	500	630	800	1000	1200	1600	2000	2500
Copper Conductor	In air (A)	587	667	764	878	1001	1126	1330	1436	1642	1809	1970
	In direct buried (A)	446	500	563	633	707	779	894	950	1052	1129	1197
	In duct (A)	465	523	593	673	760	847	1019	1095	1242	1401	1515
Aluminium Conductor	In air (A)	459	522	603	699	806	920	1115	1173	1364	1527	1661
	In direct buried (A)	350	394	447	508	575	643	757	789	889	970	1030
	In duct (A)	361	407	465	530	604	681	836	874	1002	1141	1224

* Enameled conductor Increasing current capacity approx. 10~13%

275~287kV XLPE Cable with Corrugated Aluminum Sheath

Cable type : 275~287kV Cu(or AL)/XLPE/Corrugated AL/PE(or PVC)



1. Conductor : Copper or enameled copper or aluminum
2. Conductor screen : Semi-conducting compound
3. Insulation : Cross-linked polyethylene
4. Insulation screen : Semi-conducting compound
5. Cushion layer : Semi-conducting tapes
6. Metal sheath : Corrugated aluminum
7. Outer sheath : Polyethylene or polyvinyl chloride

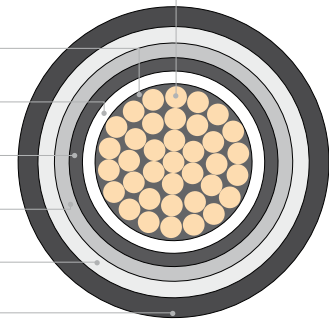

Construction Data

	Cross sectional area (mm ²)	240	300	400	500	630	800	1000	1200	1600	2000	2500	
Conductor	Shape	Circular compact stranded						Segmental stranded					
	Diameter (mm)	18.5	20.7	23.3	26.9	30.5	34.3	39.3	42.4	48.9	54.9	61.4	
Thickness of conductor screen Approx. (mm)		2.0	2.0	2.0	2.0	2.0	2.0	2.0	2.0	2.0	2.0	2.0	
Thickness of insulation (mm)		23.0	23.0	23.0	23.0	23.0	23.0	23.0	23.0	23.0	23.0	23.0	
Thickness of insulation screen Approx. (mm)		1.5	1.5	1.5	1.5	1.5	1.5	1.5	1.5	1.5	1.5	1.5	
Thickness of metal sheath (mm)		2.1	2.2	2.2	2.3	2.4	2.4	2.5	2.6	2.7	2.9	3.0	
Thickness of outer sheath (mm)		5.0	5.0	5.0	5.0	5.0	5.0	5.0	5.0	5.0	5.0	5.0	
Outer diameter of cable (mm)		107.0	110.0	113.0	117.0	121.0	125.0	131.0	135.0	142.0	149.0	156.0	
Weight of cable(Copper conductor) (kg/m)		10.3	11.3	12.4	14.0	15.9	18.1	21.1	23.2	28.0	32.9	38.7	
Weight of cable(Aluminum conductor) (kg/m)		8.8	9.4	10.0	10.9	11.9	12.9	14.4	15.5	17.6	19.9	22.0	
Max. DC Conductor resistance at 20°C (Cu, Ω/km)		0.0754	0.0601	0.047	0.0366	0.0283	0.0221	0.0176	0.0151	0.0113	0.009	0.0072	
Max. DC Conductor resistance at 20°C (AL, Ω/km)		0.125	0.100	0.0778	0.0605	0.0469	0.0367	0.0291	0.0247	0.0186	0.0149	0.0127	
Capacitance (μF/km)		0.12	0.13	0.14	0.15	0.16	0.17	0.19	0.20	0.22	0.24	0.26	

Continuous current rating(Single circuit)

	Cross sectional area (mm ²)	240	300	400	500	630	800	1000	1200	1600	2000	2500
Copper Conductor	In air (A)	580	660	755	868	989	1111	1305	1407	1600	1754	1901
	In direct buried (A)	444	497	560	630	703	772	880	932	1023	1089	1147
	In duct (A)	457	514	583	660	743	857	991	1061	1192	1341	1437
Aluminium Conductor	In air (A)	453	516	596	690	795	907	1095	1151	1332	1485	1609
	In direct buried (A)	348	391	444	505	571	637	747	776	869	943	995
	In duct (A)	356	401	457	521	592	689	817	852	971	1102	1176

* Enameled conductor Increasing current capacity approx. 10~13%

275~287kV XLPE Cable with Copper Wire Screen

Cable type : 275~287kV Cu(or AL)/XLPE/CWS/PE (or PVC)



1. Conductor : Copper or enameled copper or aluminum
2. Conductor screen : Semi-conducting compound
3. Insulation : Cross-linked polyethylene
4. Insulation screen : Semi-conducting compound
5. Cushion layer : Semi-conducting tapes
6. Metal screen : Copper wires
7. Water blocking layer : Plastic laminated aluminum foil
8. Outer sheath : Polyethylene or polyvinyl chloride

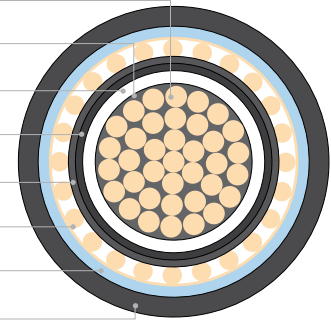

Construction Data

	Cross sectional area (mm ²)	240	300	400	500	630	800	1000	1200	1600	2000	2500	
Conductor	Shape	Circular compact stranded						Segmental stranded					
	Diameter (mm)	18.5	20.7	23.3	26.9	30.5	34.3	39.3	42.4	48.9	54.9	61.4	
Thickness of conductor screen Approx. (mm)		2.0	2.0	2.0	2.0	2.0	2.0	2.0	2.0	2.0	2.0	2.0	
Thickness of insulation (mm)		23.0	23.0	23.0	23.0	23.0	23.0	23.0	23.0	23.0	23.0	23.0	
Thickness of insulation screen Approx. (mm)		1.5	1.5	1.5	1.5	1.5	1.5	1.5	1.5	1.5	1.5	1.5	
Dia. x No. of metal screen (mm×EA)		1.2×80	1.2×80	1.2×80	1.2×80	1.2×80	1.2×80	1.2×80	1.2×80	1.2×80	1.2×80	1.2×80	
Thickness of outer sheath (mm)		5.0	5.0	5.0	5.0	5.0	5.0	5.0	5.0	5.0	5.0	5.0	
Outer diameter of cable (mm)		89.0	91.0	94.0	97.0	101.0	105.0	110.0	113.0	120.0	126.0	132.0	
Weight of cable(Copper conductor) (kg/m)		8.5	9.3	10.4	11.7	13.3	15.5	18.1	20.0	24.4	28.8	34.1	
Weight of cable(Aluminum conductor) (kg/m)		7.0	7.4	8.0	8.6	9.3	10.3	11.4	12.3	14.0	15.8	17.4	
Max. DC Conductor resistance at 20°C (Cu, Ω/km)		0.0754	0.0601	0.047	0.0366	0.0283	0.0221	0.0176	0.0151	0.0113	0.009	0.0072	
Max. DC Conductor resistance at 20°C (AL, Ω/km)		0.125	0.100	0.0778	0.0605	0.0469	0.0367	0.0291	0.0247	0.0186	0.0149	0.0127	
Capacitance (μF/km)		0.12	0.13	0.14	0.15	0.16	0.17	0.19	0.20	0.22	0.24	0.26	

Continuous current rating(Single circuit)

Cross sectional area (mm ²)		240	300	400	500	630	800	1000	1200	1600	2000	2500
Copper Conductor	In air (A)	589	672	773	893	1026	1163	1394	1516	1766	1975	2185
	In direct buried (A)	451	508	576	653	737	853	961	1031	1170	1279	1382
	In duct (A)	453	511	580	673	762	821	995	1070	1266	1396	1520
Aluminium Conductor	In air (A)	459	524	607	706	818	939	1151	1215	1432	1623	1783
	In direct buried (A)	352	396	453	517	589	664	795	831	955	1059	1139
	In duct (A)	353	397	453	529	604	682	814	851	1013	1128	1261

* Enameled conductor Increasing current capacity approx. 10~13%

275~287kV XLPE Cable with Lead alloy Sheath

Cable type : 275~287kV Cu(or AL)/XLPE/Lead alloy/PE(or PVC)



1. Conductor : Copper or enameled copper or aluminum
2. Conductor screen : Semi-conducting compound
3. Insulation : Cross-linked polyethylene
4. Insulation screen : Semi-conducting compound
5. Cushion layer : Semi-conducting tapes
6. Metal sheath : Lead alloy
7. Outer sheath : Polyethylene or polyvinyl chloride

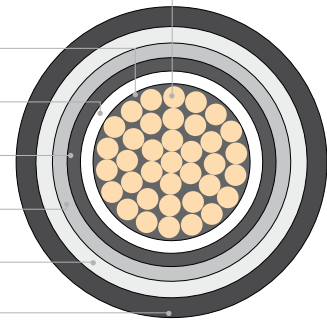

Construction Data

	Cross sectional area (mm ²)	240	300	400	500	630	800	1000	1200	1600	2000	2500	
Conductor	Shape	Circular compact stranded						Segmental stranded					
	Diameter (mm)	18.5	20.7	23.3	26.9	30.5	34.3	39.3	42.4	48.9	54.9	61.4	
Thickness of conductor screen Approx. (mm)		2.0	2.0	2.0	2.0	2.0	2.0	2.0	2.0	2.0	2.0	2.0	
Thickness of insulation (mm)		23.0	23.0	23.0	23.0	23.0	23.0	23.0	23.0	23.0	23.0	23.0	
Thickness of insulation screen Approx. (mm)		1.5	1.5	1.5	1.5	1.5	1.5	1.5	1.5	1.5	1.5	1.5	
Thickness of metal sheath (mm)		2.8	2.9	2.9	3.0	3.1	3.2	3.3	3.5	3.7	3.9	4.1	
Thickness of outer sheath (mm)		5.0	5.0	5.0	5.0	5.0	5.0	5.0	5.0	5.0	5.0	5.0	
Outer diameter of cable (mm)		100.0	103.0	105.0	109.0	113.0	117.0	123.0	126.0	133.0	139.0	146.0	
Weight of cable(Copper conductor) (kg/m)		16.3	17.5	19.1	21.1	23.5	26.4	30.2	33.3	39.3	45.3	52.5	
Weight of cable(Aluminum conductor) (kg/m)		14.8	15.6	16.7	18.0	19.5	21.2	23.5	25.5	29.0	32.3	35.8	
Max. DC Conductor resistance at 20°C (Cu, Ω/km)		0.0754	0.0601	0.047	0.0366	0.0283	0.0221	0.0176	0.0151	0.0113	0.009	0.0072	
Max. DC Conductor resistance at 20°C (AL, Ω/km)		0.125	0.100	0.0778	0.0605	0.0469	0.0367	0.0291	0.0247	0.0186	0.0149	0.0127	
Capacitance (μF/km)		0.12	0.13	0.14	0.15	0.16	0.17	0.19	0.20	0.22	0.24	0.26	

Continuous current rating(Single circuit)

	Cross sectional area (mm ²)	240	300	400	500	630	800	1000	1200	1600	2000	2500
Copper Conductor	In air (A)	591	675	776	898	1032	1171	1401	1523	1769	1970	2166
	In direct buried (A)	453	511	580	658	743	828	968	1037	1170	1270	1360
	In duct (A)	454	511	580	673	763	853	995	1069	1263	1387	1502
Aluminium Conductor	In air (A)	460	525	608	708	821	943	1156	1219	1434	1621	1774
	In direct buried (A)	353	398	455	520	593	669	799	835	956	1055	1127
	In duct (A)	353	397	454	529	604	683	814	851	1011	1124	1207

* Enameled conductor Increasing current capacity approx. 10~13%

275~287kV XLPE Cable with Smoothed Aluminum Sheath

Cable type : 275~287kV Cu(or AL)/XLPE/Smoothed AL/PE(or FR-PE)



1. Conductor : Copper or enameled copper or aluminum
2. Conductor screen : Semi-conducting compound
3. Insulation : Cross-linked polyethylene
4. Insulation screen : Semi-conducting compound
5. Cushion layer : Semi-conducting tapes
6. Metal sheath : Smoothed aluminum
7. Outer sheath : Polyethylene or Flame retardant polyethylene

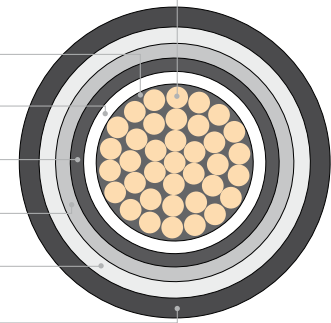

Construction Data

	Cross sectional area (mm ²)	240	300	400	500	630	800	1000	1200	1600	2000	2500	
Conductor	Shape	Circular compact stranded						Segmental stranded					
	Diameter (mm)	18.5	20.7	23.3	26.9	30.5	34.3	39.3	42.4	48.9	54.9	61.4	
Thickness of conductor screen Approx. (mm)		2.0	2.0	2.0	2.0	2.0	2.0	2.0	2.0	2.0	2.0	2.0	
Thickness of insulation (mm)		23.0	23.0	23.0	23.0	23.0	23.0	23.0	23.0	23.0	23.0	23.0	
Thickness of insulation screen Approx. (mm)		1.5	1.5	1.5	1.5	1.5	1.5	1.5	1.5	1.5	1.5	1.5	
Thickness of metal sheath (mm)		2.5	2.4	2.3	2.2	2.1	2.1	1.9	1.9	1.8	1.7	1.6	
Thickness of outer sheath (mm)		6.0	6.0	6.0	6.0	6.0	6.0	6.0	6.0	6.0	6.0	6.0	
Outer diameter of cable (mm)		96.0	98.0	100.0	104.0	107.0	111.0	116.0	119.0	126.0	131.0	138.0	
Weight of cable(Copper conductor) (kg/m)		9.2	10.0	11.0	12.3	13.9	16.0	18.6	20.6	24.9	29.3	34.6	
Weight of cable(Aluminum conductor) (kg/m)		7.7	8.1	8.5	9.2	9.9	10.8	12.0	12.8	14.6	16.3	17.9	
Max. DC Conductor resistance at 20°C (Cu, Ω/km)		0.0754	0.0601	0.047	0.0366	0.0283	0.0221	0.0176	0.0151	0.0113	0.009	0.0072	
Max. DC Conductor resistance at 20°C (AL, Ω/km)		0.125	0.100	0.0778	0.0605	0.0469	0.0367	0.0291	0.0247	0.0186	0.0149	0.0127	
Capacitance (μF/km)		0.12	0.13	0.14	0.15	0.16	0.17	0.19	0.20	0.22	0.24	0.26	

Continuous current rating(Single circuit)

Cross sectional area (mm ²)		240	300	400	500	630	800	1000	1200	1600	2000	2500
Copper Conductor	In air (A)	583	662	759	872	995	1118	1322	1426	1632	1800	1963
	In direct buried (A)	443	495	559	629	703	773	889	942	1044	1120	1189
	In duct (A)	460	517	587	665	750	866	1005	1079	1221	1378	1489
Aluminium Conductor	In air (A)	456	519	599	694	801	914	1108	1165	1355	1518	1653
	In direct buried (A)	348	392	444	505	571	638	752	782	882	963	1023
	In duct (A)	358	403	460	525	597	695	827	863	989	1125	1206

* Enameled conductor Increasing current capacity approx. 10~13%

330~345kV XLPE Cable with Corrugated Aluminum Sheath

Cable type : 330~345kV Cu(or AL)/XLPE/Corrugated AL/PE(or PVC)



1. Conductor : Copper or enameled copper or aluminum
2. Conductor screen : Semi-conducting compound
3. Insulation : Cross-linked polyethylene
4. Insulation screen : Semi-conducting compound
5. Cushion layer : Semi-conducting tapes
6. Metal sheath : Corrugated aluminum
7. Outer sheath : Polyethylene or polyvinyl chloride

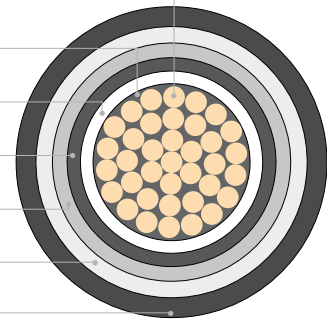

Construction Data

	Cross sectional area (mm ²)	400	500	630	800	1000	1200	1600	2000	2500
Conductor	Shape	Circular compact stranded				Segmental stranded				
	Diameter (mm)	23.3	26.9	30.5	34.3	39.3	42.4	48.9	54.9	61.4
Thickness of conductor screen Approx.	(mm)	2.0	2.0	2.0	2.0	2.0	2.0	2.0	2.0	2.0
Thickness of insulation	(mm)	27.0	27.0	27.0	27.0	27.0	27.0	27.0	27.0	27.0
Thickness of insulation screen Approx.	(mm)	1.5	1.5	1.5	1.5	1.5	1.5	1.5	1.5	1.5
Thickness of metal sheath	(mm)	2.4	2.4	2.5	2.6	2.7	2.8	2.9	3.0	3.1
Thickness of outer sheath	(mm)	6.0	6.0	6.0	6.0	6.0	6.0	6.0	6.0	6.0
Outer diameter of cable	(mm)	124.0	127.0	132.0	136.0	142.0	146.0	153.0	160.0	167.0
Weight of cable(Copper conductor)	(kg/m)	14.6	16.1	18.1	20.5	23.6	25.8	30.7	35.6	41.4
Weight of cable(Aluminum conductor)	(kg/m)	12.2	13.0	14.1	15.3	16.9	18.1	20.4	22.6	24.7
Max. DC Conductor resistance at 20°C	(Cu, Ω/km)	0.047	0.0366	0.0283	0.0221	0.0176	0.0151	0.0113	0.009	0.0072
Max. DC Conductor resistance at 20°C	(AL, Ω/km)	0.0778	0.0605	0.0469	0.0367	0.0291	0.0247	0.0186	0.0149	0.0127
Capacitance	(μF/km)	0.13	0.14	0.15	0.16	0.17	0.18	0.20	0.21	0.23

Continuous current rating(Single circuit)

Cross sectional area (mm ²)	400	500	630	800	1000	1200	1600	2000	2500	
Copper Conductor	In air (A)	746	856	976	1097	1287	1386	1581	1737	1886
	In direct buried (A)	553	622	694	763	868	918	1011	1077	1137
	In duct (A)	588	667	753	838	993	1063	1199	1301	1391
Aluminium Conductor	In air (A)	588	681	784	894	1079	1133	1314	1466	1590
	In direct buried (A)	439	499	564	630	737	765	858	932	985
	In duct (A)	461	526	599	675	818	853	974	1073	1143

* Enameled conductor Increasing current capacity approx. 10~13%

330~345kV XLPE Cable with Copper Wire Screen

Cable type : 330~345kV Cu(or AL)/XLPE/CWS/PE (or PVC)



1. Conductor : Copper or enameled copper or aluminum
2. Conductor screen : Semi-conducting compound
3. Insulation : Cross-linked polyethylene
4. Insulation screen : Semi-conducting compound
5. Cushion layer : Semi-conducting tapes
6. Metal screen : Copper wires
7. Water blocking layer : Plastic laminted aluminum foil
8. Outer sheath : Polyethylene or polyvinyl chloride

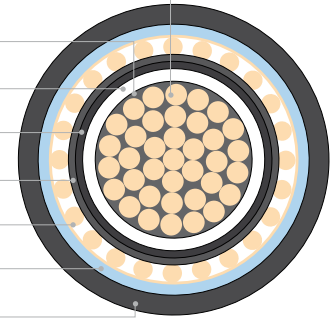

Construction Data

	Cross sectional area (mm ²)	400	500	630	800	1000	1200	1600	2000	2500
Conductor	Shape	Circular compact stranded				Segmental stranded				
	Diameter (mm)	23.3	26.9	30.5	34.3	39.3	42.4	48.9	54.9	61.4
Thickness of conductor screen Approx. (mm)		2.0	2.0	2.0	2.0	2.0	2.0	2.0	2.0	2.0
Thickness of insulation (mm)		27.0	27.0	27.0	27.0	27.0	27.0	27.0	27.0	27.0
Thickness of insulation screen Approx. (mm)		1.5	1.5	1.5	1.5	1.5	1.5	1.5	1.5	1.5
Dia. x No. of metal screen (mmxEA)		1.2x8.0	1.2 x 80	1.2 x 80	1.2 x 80	1.2 x 80	1.2 x 80	1.2 x 80	1.2 x 80	1.2 x 80
Thickness of outer sheath (mm)		6.0	6.0	6.0	6.0	6.0	6.0	6.0	6.0	6.0
Outer diameter of cable (mm)		104.0	107.0	111.0	115.0	120.0	123.0	130.0	136.0	142.0
Weight of cable(Copper conductor) (kg/m)		11.9	13.3	15.0	17.2	19.9	21.9	26.4	30.9	36.3
Weight of cable(Aluminum conductor) (kg/m)		9.5	10.2	11.0	12.1	13.3	14.2	16.0	17.8	19.6
Max. DC Conductor resistance at 20°C (Cu, Ω/km)		0.0470	0.0366	0.0283	0.0221	0.0176	0.0151	0.0113	0.009	0.0072
Max. DC Conductor resistance at 20°C (AL, Ω/km)		0.0778	0.0605	0.0469	0.0367	0.0291	0.0247	0.0186	0.0149	0.0127
Capacitance (μF/km)		0.13	0.14	0.15	0.16	0.17	0.18	0.20	0.21	0.23

Continuous current rating(Single circuit)

Cross sectional area (mm ²)		400	500	630	800	1000	1200	1600	2000	2500
Copper Conductor	In air (A)	768	888	1022	1161	1392	1517	1774	1993	2214
	In direct buried (A)	575	653	739	826	969	1044	1191	1310	1425
	In duct (A)	584	663	751	841	1012	1091	1250	1413	1545
Aluminium Conductor	In air (A)	601	700	812	933	1144	1208	1428	1622	1787
	In direct buried (A)	451	515	588	664	797	834	962	1071	1156
	In duct (A)	456	521	594	672	826	864	998	1137	1228

* Enameled conductor Increasing current capacity approx. 10~13%

330~345kV XLPE Cable with Lead alloy Sheath

Cable type : 330~345kV Cu(or AL)/XLPE/Lead alloy/PE(or PVC)



1. Conductor : Copper or enameled copper or aluminum
2. Conductor screen : Semi-conducting compound
3. Insulation : Cross-linked polyethylene
4. Insulation screen : Semi-conducting compound
5. Cushion layer : Semi-conducting tapes
6. Metal sheath : Lead alloy
7. Outer sheath : Polyethylene or polyvinyl chloride

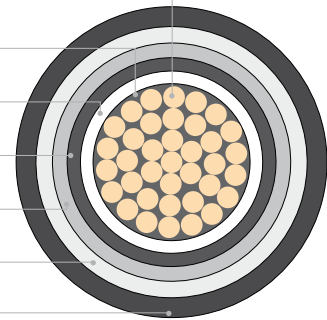

Construction Data

	Cross sectional area (mm ²)	400	500	630	800	1000	1200	1600	2000	2500
Conductor	Shape	Circular compact stranded				Segmental stranded				
	Diameter (mm)	23.3	26.9	30.5	34.3	39.3	42.4	48.9	54.9	61.4
Thickness of conductor screen Approx.	(mm)	2.0	2.0	2.0	2.0	2.0	2.0	2.0	2.0	2.0
Thickness of insulation	(mm)	27.0	27.0	27.0	27.0	27.0	27.0	27.0	27.0	27.0
Thickness of insulation screen Approx.	(mm)	1.5	1.5	1.5	1.5	1.5	1.5	1.5	1.5	1.5
Thickness of metal sheath	(mm)	3.2	3.3	3.4	3.5	3.6	3.8	4.0	4.2	4.4
Thickness of outer sheath	(mm)	6.0	6.0	6.0	6.0	6.0	6.0	6.0	6.0	6.0
Outer diameter of cable	(mm)	116.0	120.0	123.0	127.0	133.0	137.0	144.0	150.0	157.0
Weight of cable(Copper conductor)	(kg/m)	22.5	24.6	27.1	30.1	34.0	37.3	43.5	49.7	57.1
Weight of cable(Aluminum conductor)	(kg/m)	20.0	21.5	23.1	24.9	27.4	29.5	33.2	36.7	40.4
Max. DC Conductor resistance at 20°C	(Cu, Ω/km)	0.047	0.0366	0.0283	0.0221	0.0176	0.0151	0.0113	0.009	0.0072
Max. DC Conductor resistance at 20°C	(AL, Ω/km)	0.0778	0.0605	0.0469	0.0367	0.0291	0.0247	0.0186	0.0149	0.0127
Capacitance	(μF/km)	0.13	0.14	0.15	0.16	0.17	0.18	0.20	0.21	0.23

Continuous current rating(Single circuit)

	Cross sectional area (mm ²)	400	500	630	800	1000	1200	1600	2000	2500
Copper Conductor	In air (A)	767	886	1018	1155	1378	1497	1737	1933	2125
	In direct buried (A)	574	651	734	818	953	1021	1150	1247	1333
	In duct (A)	582	661	748	863	1006	1082	1263	1388	1505
Aluminium Conductor	In air (A)	601	699	810	929	1137	1199	1408	1590	1739
	In direct buried (A)	450	514	586	661	788	823	941	1037	1106
	In duct (A)	455	520	593	689	823	860	989	1124	1208

* Enameled conductor Increasing current capacity approx. 10~13%

330~345kV XLPE Cable with Smoothed Aluminum Sheath

Cable type : 330~345kV Cu(or AL)/XLPE/Smoothed AL/PE(or FR-PE)



1. Conductor : Copper or enameled copper or aluminum
2. Conductor screen : Semi-conducting compound
3. Insulation : Cross-linked polyethylene
4. Insulation screen : Semi-conducting compound
5. Cushion layer : Semi-conducting tapes
6. Metal sheath : Smoothed aluminum
7. Outer sheath : Polyethylene or Flame retardant polyethylene

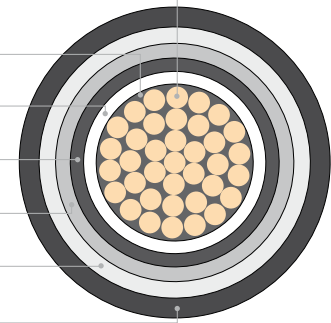

Construction Data

	Cross sectional area (mm ²)	400	500	630	800	1000	1200	1600	2000	2500
Conductor	Shape	Circular compact stranded				Segmental stranded				
	Diameter (mm)	23.3	26.9	30.5	34.3	39.3	42.4	48.9	54.9	61.4
Thickness of conductor screen Approx. (mm)		2.0	2.0	2.0	2.0	2.0	2.0	2.0	2.0	2.0
Thickness of insulation (mm)		27.0	27.0	27.0	27.0	27.0	27.0	27.0	27.0	27.0
Thickness of insulation screen Approx. (mm)		1.5	1.5	1.5	1.5	1.5	1.5	1.5	1.5	1.5
Thickness of metal sheath (mm)		2.1	2.0	2.0	1.9	1.8	1.7	1.6	1.6	1.5
Thickness of outer sheath (mm)		6.0	6.0	6.0	6.0	6.0	6.0	6.0	6.0	6.0
Outer diameter of cable (mm)		108.0	111.0	115.0	119.0	124.0	127.0	133.0	139.0	145.0
Weight of cable(Copper conductor) (kg/m)		12.0	13.4	15.2	17.2	20.0	21.8	26.3	30.8	36.1
Weight of cable(Aluminum conductor) (kg/m)		9.6	10.3	11.2	12.0	13.3	14.1	15.9	17.8	19.4
Max. DC Conductor resistance at 20°C (Cu, Ω/km)		0.047	0.0366	0.0283	0.0221	0.0176	0.0151	0.0113	0.009	0.0072
Max. DC Conductor resistance at 20°C (AL, Ω/km)		0.0778	0.0605	0.0469	0.0367	0.0291	0.0247	0.0186	0.0149	0.0127
Capacitance (μF/km)		0.13	0.14	0.15	0.16	0.17	0.18	0.20	0.21	0.23

Continuous current rating(Single circuit)

Cross sectional area (mm ²)		400	500	630	800	1000	1200	1600	2000	2500
Copper Conductor	In air (A)	750	862	984	1108	1307	1414	1622	1785	1950
	In direct buried (A)	555	624	697	769	881	938	1041	1113	1183
	In duct (A)	593	673	760	849	1008	1084	1231	1343	1448
Aluminium Conductor	In air (A)	592	686	791	903	1094	1152	1341	1501	1635
	In direct buried (A)	440	500	566	633	745	776	877	954	1014
	In duct (A)	464	530	604	682	828	865	993	1098	1176

* Enameled conductor Increasing current capacity approx. 10~13%

380~400kV XLPE Cable with Corrugated Aluminum Sheath

Cable type : 380~400kV Cu(or AL)/XLPE/Corrugated AL/PE(or PVC)



1. Conductor : Copper or enameled copper or aluminum
2. Conductor screen : Semi-conducting compound
3. Insulation : Cross-linked polyethylene
4. Insulation screen : Semi-conducting compound
5. Cushion layer : Semi-conducting tapes
6. Metal sheath : Corrugated aluminum
7. Outer sheath : Polyethylene or polyvinyl chloride

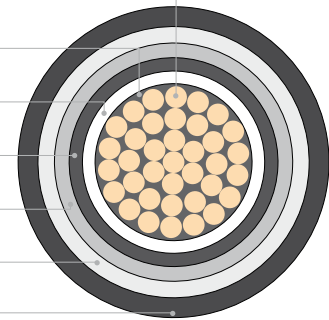

Construction Data

	Cross sectional area (mm ²)	630	800	1000	1200	1600	2000	2500
Conductor	Shape	Circular compact stranded			Segmental stranded			
	Diameter (mm)	30.5	34.3	39.3	42.4	48.9	54.9	61.4
Thickness of conductor screen Approx.	(mm)	2.0	2.0	2.0	2.0	2.0	2.0	2.0
Thickness of insulation	(mm)	32.0	30.0	29.0	27.0	27.0	27.0	27.0
Thickness of insulation screen Approx.	(mm)	1.5	1.5	1.5	1.5	1.5	1.5	1.5
Thickness of metal sheath	(mm)	2.7	2.7	2.8	2.8	2.9	3.0	3.1
Thickness of outer sheath	(mm)	6.0	6.0	6.0	6.0	6.0	6.0	6.0
Outer diameter of cable	(mm)	143.0	143.0	147.0	146.0	153.0	160.0	167.0
Weight of cable(Copper conductor)	(kg/m)	20.4	21.8	24.6	25.8	30.7	35.6	41.4
Weight of cable(Aluminum conductor)	(kg/m)	16.4	16.7	18.0	18.1	20.4	22.6	24.7
Max. DC Conductor resistance at 20°C	(Cu, Ω/km)	0.0283	0.0221	0.0176	0.0151	0.0113	0.009	0.0072
Max. DC Conductor resistance at 20°C	(AL, Ω/km)	0.0469	0.0367	0.0291	0.0247	0.0186	0.0149	0.0127
Capacitance	(μF/km)	0.13	0.15	0.16	0.18	0.20	0.21	0.23

Continuous current rating(Single circuit)

	Cross sectional area (mm ²)	630	800	1000	1200	1600	2000	2500
Copper Conductor	In air (A)	964	1087	1276	1378	1571	1726	1874
	In direct buried (A)	687	754	856	905	995	1059	1117
	In duct (A)	739	824	977	1049	1182	1281	1368
Aluminium Conductor	In air (A)	775	886	1070	1126	1306	1457	1580
	In direct buried (A)	559	623	727	754	845	916	967
	In duct (A)	589	664	805	842	960	1056	1124

* Enameled conductor Increasing current capacity approx. 10~13%

380~400kV XLPE Cable with Copper Wire Screen

Cable type : 380~400kV Cu(or AL)/XLPE/CWS/PE (or PVC)



1. Conductor : Copper or enameled copper or aluminum
2. Conductor screen : Semi-conducting compound
3. Insulation : Cross-linked polyethylene
4. Insulation screen : Semi-conducting compound
5. Cushion layer : Semi-conducting tapes
6. Metal screen : Copper wires
7. Water blocking layer : Plastic laminted aluminum foil
8. Outer sheath : Polyethylene or polyvinyl chloride

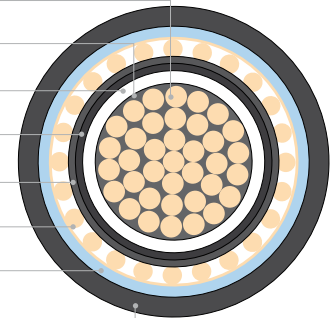

Construction Data

	Cross sectional area (mm ²)	630	800	1000	1200	1600	2000	2500	
Conductor	Shape	Circular compact stranded			Segmental stranded				
	Diameter (mm)	30.5	34.3	39.3	42.4	48.9	54.9	61.4	
Thickness of conductor screen Approx. (mm)		2.0	2.0	2.0	2.0	2.0	2.0	2.0	
Thickness of insulation (mm)		32.0	30.0	29.0	27.0	27.0	27.0	27.0	
Thickness of insulation screen Approx. (mm)		1.5	1.5	1.5	1.5	1.5	1.5	1.5	
Dia. x No. of metal screen (mmxEA)		1.2 x 80	1.2 x 80	1.2 x 80	1.2 x 80	1.2 x 80	1.2 x 80	1.2 x 80	
Thickness of outer sheath (mm)		6.0	6.0	6.0	6.0	6.0	6.0	6.0	
Outer diameter of cable (mm)		121.0	121.0	124.0	123.0	130.0	136.0	142.0	
Weight of cable(Copper conductor) (kg/m)		16.7	18.3	20.6	21.9	26.4	30.9	36.3	
Weight of cable(Aluminum conductor) (kg/m)		12.7	13.1	14.0	14.2	16.0	17.8	19.6	
Max. DC Conductor resistance at 20°C (Cu, Ω/km)		0.0283	0.0221	0.0176	0.0151	0.0113	0.009	0.0072	
Max. DC Conductor resistance at 20°C (AL, Ω/km)		0.0469	0.0367	0.0291	0.0247	0.0186	0.0149	0.0127	
Capacitance (μF/km)		0.13	0.15	0.16	0.18	0.20	0.21	0.23	

Continuous current rating(Single circuit)

Cross sectional area (mm ²)	630	800	1000	1200	1600	2000	2500	
Copper Conductor	In air (A)	1004	1142	1365	1489	1735	1941	2149
	In direct buried (A)	728	809	942	1008	1142	1249	1350
	In duct (A)	759	851	993	1070	1221	1379	1502
Aluminium Conductor	In air (A)	798	919	1129	1191	1403	1590	1747
	In direct buried (A)	580	653	776	811	931	1031	1108
	In duct (A)	601	680	812	849	978	1113	1199

* Enameled conductor Increasing current capacity approx. 10~13%

380~400kV XLPE Cable with Lead alloy Sheath

Cable type : 380~400kV Cu(or AL)/XLPE/Lead alloy/PE(or PVC)



1. Conductor : Copper or enameled copper or aluminum
2. Conductor screen : Semi-conducting compound
3. Insulation : Cross-linked polyethylene
4. Insulation screen : Semi-conducting compound
5. Cushion layer : Semi-conducting tapes
6. Metal sheath : Lead alloy
7. Outer sheath : Polyethylene or polyvinyl chloride

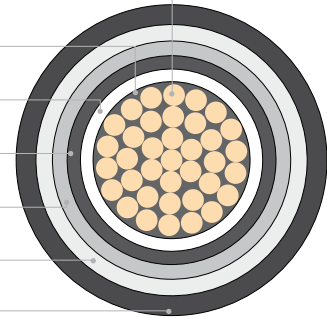

Construction Data

		630	800	1000	1200	1600	2000	2500
Conductor	Cross sectional area (mm ²)							
	Shape	Circular compact stranded			Segmental stranded			
	Diameter (mm)	30.5	34.3	39.3	42.4	48.9	54.9	61.4
	Thickness of conductor screen Approx. (mm)	2.0	2.0	2.0	2.0	2.0	2.0	2.0
	Thickness of insulation (mm)	32.0	30.0	29.0	27.0	27.0	27.0	27.0
	Thickness of insulation screen Approx. (mm)	1.5	1.5	1.5	1.5	1.5	1.5	1.5
	Thickness of metal sheath (mm)	2.7	2.7	2.8	2.8	2.9	3.0	3.1
	Thickness of outer sheath (mm)	6.0	6.0	6.0	6.0	6.0	6.0	6.0
	Outer diameter of cable (mm)	143.0	143.0	147.0	146.0	153.0	160.0	167.0
	Weight of cable(Copper conductor) (kg/m)	20.4	21.8	24.6	25.8	30.7	35.6	41.4
	Weight of cable(Aluminum conductor) (kg/m)	16.4	16.7	18.0	18.1	20.4	22.6	24.7
	Max. DC Conductor resistance at 20°C (Cu, Ω/km)	0.0283	0.0221	0.0176	0.0151	0.0113	0.009	0.0072
	Max. DC Conductor resistance at 20°C (AL, Ω/km)	0.0469	0.0367	0.0291	0.0247	0.0186	0.0149	0.0127
	Capacitance (μF/km)	0.13	0.15	0.16	0.18	0.20	0.21	0.23

Continuous current rating(Single circuit)

		630	800	1000	1200	1600	2000	2500
Copper Conductor	Cross sectional area (mm ²)							
	In air (A)	964	1087	1276	1378	1571	1726	1874
	In direct buried (A)	687	754	856	905	995	1059	1117
	In duct (A)	739	824	977	1049	1182	1281	1368
Aluminium Conductor	In air (A)	775	886	1070	1126	1306	1457	1580
	In direct buried (A)	559	623	727	754	845	916	967
	In duct (A)	589	664	805	842	960	1056	1124

* Enameled conductor Increasing current capacity approx. 10~13%

380~400kV XLPE Cable with Smoothed Aluminum Sheath

Cable type : 380~400kV Cu(or AL)/XLPE/Smoothed AL/PE(or FR-PE)



1. Conductor : Copper or enameled copper or aluminum
2. Conductor screen : Semi-conducting compound
3. Insulation : Cross-linked polyethylene
4. Insulation screen : Semi-conducting compound
5. Cushion layer : Semi-conducting tapes
6. Metal sheath : Smoothed aluminum
7. Outer sheath : Polyethylene or Flame retardant polyethylene

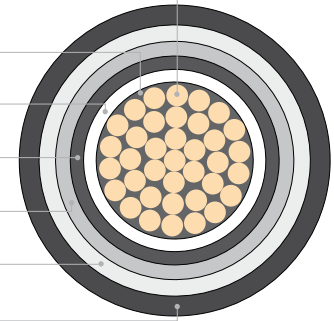

Construction Data

		630	800	1000	1200	1600	2000	2500
	Cross sectional area (mm ²)							
Conductor	Shape	Circular compact stranded			Segmental stranded			
	Diameter (mm)	30.5	34.3	39.3	42.4	48.9	54.9	61.4
	Thickness of conductor screen Approx. (mm)	2.0	2.0	2.0	2.0	2.0	2.0	2.0
	Thickness of insulation (mm)	32.0	30.0	29.0	27.0	27.0	27.0	27.0
	Thickness of insulation screen Approx. (mm)	1.5	1.5	1.5	1.5	1.5	1.5	1.5
	Thickness of metal sheath (mm)	1.8	1.8	1.7	1.7	1.6	1.6	1.5
	Thickness of outer sheath (mm)	6.0	6.0	6.0	6.0	6.0	6.0	6.0
	Outer diameter of cable (mm)	125.0	124.0	128.0	127.0	133.0	139.0	145.0
	Weight of cable(Copper conductor) (kg/m)	16.8	18.2	20.6	21.8	26.3	30.8	36.1
	Weight of cable(Aluminum conductor) (kg/m)	12.8	13.0	14.0	14.1	15.9	17.8	19.4
	Max. DC Conductor resistance at 20°C (Cu, Ω/km)	0.0283	0.0221	0.0176	0.0151	0.0113	0.009	0.0072
	Max. DC Conductor resistance at 20°C (AL, Ω/km)	0.0469	0.0367	0.0291	0.0247	0.0186	0.0149	0.0127
	Capacitance (μF/km)	0.13	0.15	0.16	0.18	0.20	0.21	0.23

Continuous current rating(Single circuit)

		630	800	1000	1200	1600	2000	2500
	Cross sectional area (mm ²)							
Copper Conductor	In air (A)	974	1099	1298	1405	1612	1774	1938
	In direct buried (A)	693	762	873	924	1025	1094	1162
	In duct (A)	748	836	994	1069	1213	1322	1424
Aluminium Conductor	In air (A)	782	895	1086	1145	1333	1491	1624
	In direct buried (A)	562	628	737	765	863	938	996
	In duct (A)	595	672	817	854	979	1082	1157

* Enameled conductor Increasing current capacity approx. 10~13%

Continuous Current Rating Capacity

The continuous current rating is calculated in accordance with IEC 60287.

Laying conditions

The technical data which appears in the preceding pages is calculated based on the following laying conditions:

1) Ground temperature : 30°C	2) Ambient temperature : 40°C	3) Soil thermal resistivity : 1.2K.m/W
4) Depth of laying : 1.2m	5) Installation formation : Trefoil formation	6) Max. conductor temperature : 90°C
7) Frequency : 50Hz	8) Load factor : 100%	9) Sheath ground : Cross bonding

Correction factor for various laying Condition

Ambient temperature (°C)	25	30	35	40	45	50	55
Correction factor	1.16	1.11	1.06	1.00	0.94	0.88	0.82
Ground temperature (°C)	20	25	30	35	40	45	50
Correction factor	1.08	1.04	1.00	0.96	0.91	0.87	0.82
Thermal resistivity of soil (k.m/w)	0.8	1.0	1.2	1.5	2.0	2.5	3.0
Correction factor	1.16	1.07	1.00	0.92	0.82	0.74	0.69
Depth of laying (m)	0.5	0.8	1.0	1.2	1.5	2.0	2.5
Correction factor	1.10	1.05	1.02	1.00	0.98	0.95	0.93

Other Cables

* Technical data for the cables below is available upon request.



Enamelled
conductor type



Corrugated Cu type



Wire shield + Lead alloy
+ Aluminum armour type



FOC embedded type
(for DTS or DRS)

Short Circuit Current Rating

The short circuit current rating is calculated in accordance with IEC 60949.

Laying conditions

$$I = \epsilon \frac{KS}{\sqrt{t}} \sqrt{\ln \left(\frac{\theta_f + \beta}{\theta_i + \beta} \right)}$$

- | | |
|---|----------------------------------|
| 1) I : Short circuit current rating | [A] |
| 2) ε : Factor to allow for heat loss into adjacent components | |
| 3) K: Constant depending on the material of the current carrying component | [Copper : 226, Aluminum : 148] |
| 4) S : Geometrical cross-sectional area of conductor | [mm ²] |
| 5) t : Duration of short circuit | [sec] |
| 6) θ _f : Final temperature | [°C] |
| 7) θ _i : Initial temperature | [°C] |
| 8) β : Reciprocal of temperature coefficient of resistance of the current carrying component at 0°C | [Copper : 234.5, Aluminum : 228] |

Short circuit current rating of conductor

Copper conductor

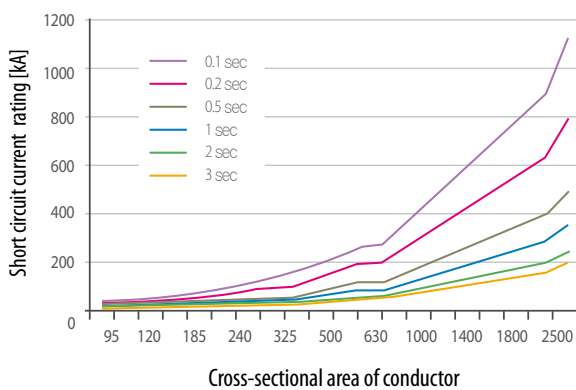

Aluminum Conductor

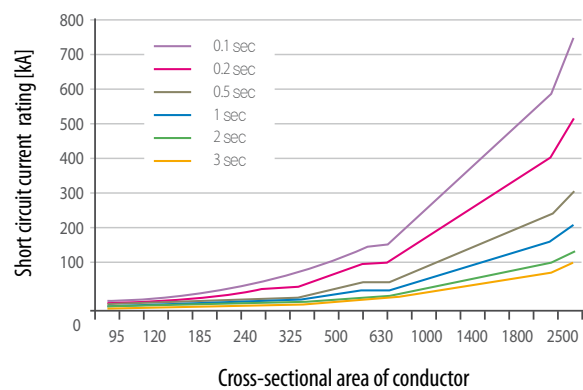

4. Accessories of EHV Cable System

Outdoor termination (EB-A)	45
SF6 Gas immersed termination (EB-G)	46
Oil immersed termination (EB-O)	47
Pre moulded joint (PMJ)	48
Pre fabricated joint (PJ)	49
Link box	50
Others	51

Outdoor termination (EB-A)

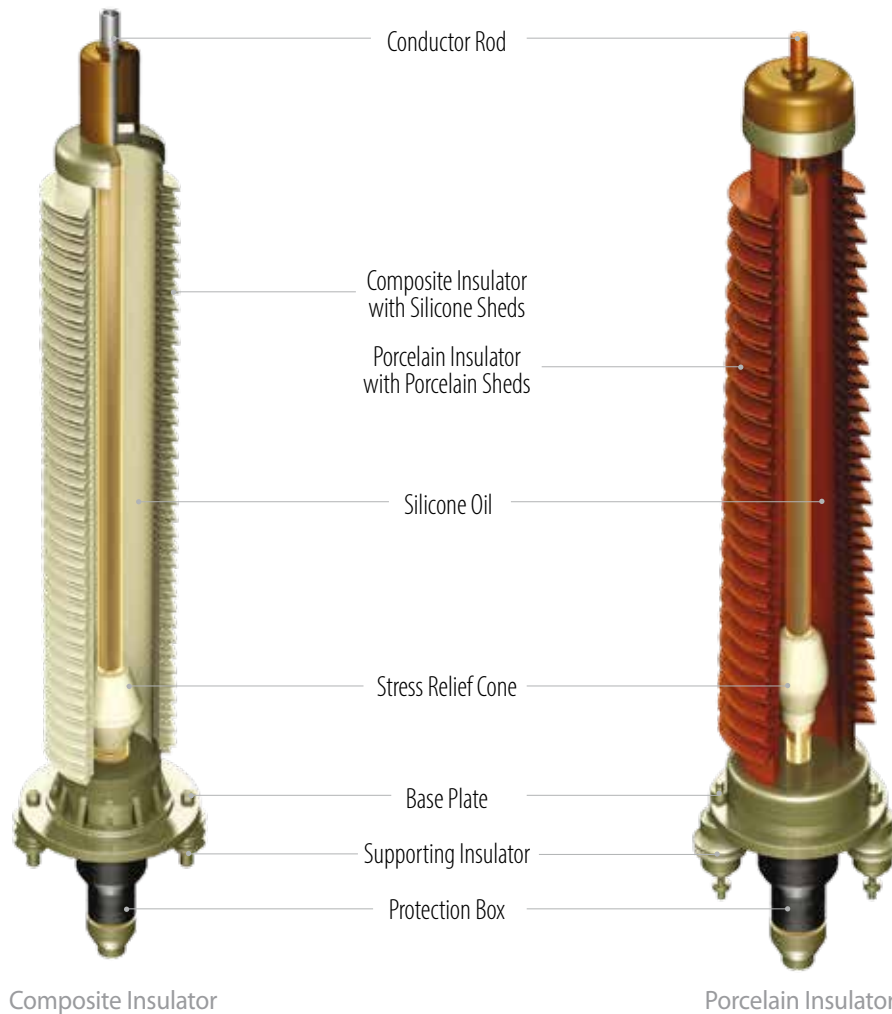

Ratings & Dimensions

Rated voltage	(kV)	60 ~ 69	110 ~ 115	132 ~ 138	150 ~ 161	220 ~ 230	330 ~ 345	380 ~ 400	
Maximum voltage	(kV)	72.5	123	145	170	245	362	420	
BIL	(kV)	325	550	650	750	1050	1175	1425	
Conductor size	(mm ²)	100 ~ 2500							
Approx. Dimension	Porcelain	Approx. Length	1395	1845	2045	2345	2875	4925	4925
		Approx. Wength	200	295	350	500	650	1550	1550
	Composite	Approx. Length	1325	1645	1965	2375	3145	5130	5130
		Approx. Wength	115	215	235	316	550	945	945

Three-piece prefabricated type or *one-piece premolded type* is applicable for both composite and porcelain insulator

Pollution Levels of Selected Insulators (Based on IEC60815)

Pollution level	I - Light	II - Medium	III - Heavy	IV - Very Heavy
Min. nominal specific creepage distance (mm/kV)	16	20	25	31

SF-6 Gas immersed termination (EB-G)

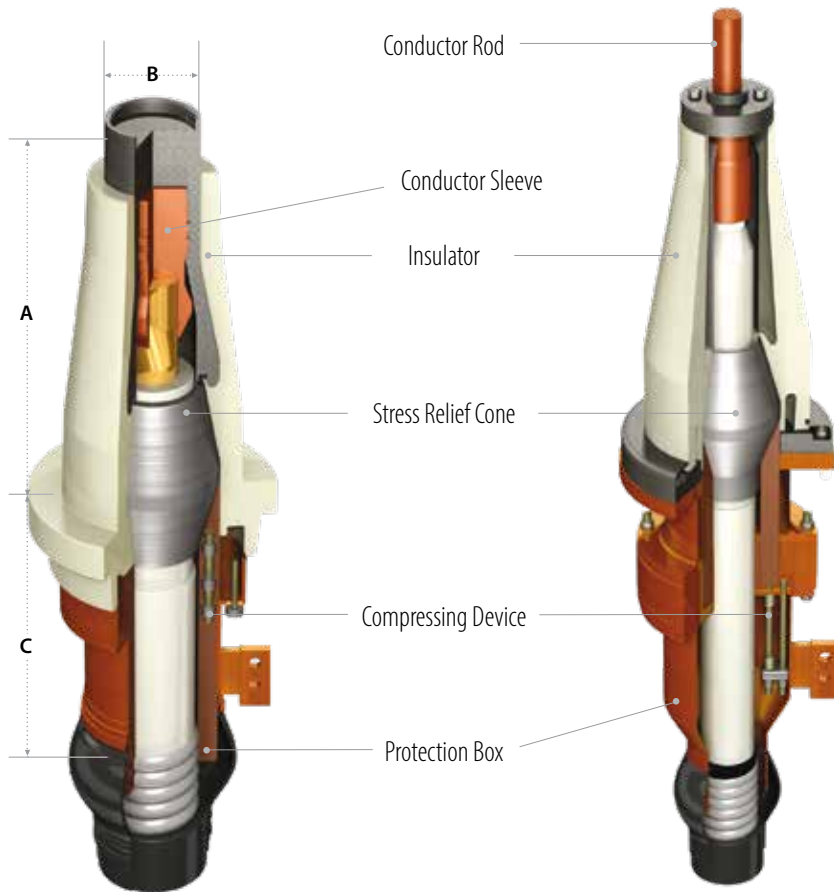

Plug-in type (IEC Type)

Compressing Leading
Conductor Type
(Non-IEC Type)

Ratings & Dimensions

Rated voltage	(kV)	60 ~ 69	110 ~ 115	132 ~ 138	150 ~ 161	220 ~ 230	330 ~ 345	380 ~ 400
Maximum voltage	(kV)	72.5	123	145	170	245	362	420
BIL	(kV)	325	550	650	750	1050	1175	1425
Conductor size	(mm ²)	100 ~ 2500						
Approx. Dimension	A (Dry type)	310	470	470	470	620	960	960
	A (Fluid type)	583	757	757	757	960	1400	1400
	B	110	110	110	110	200	250	250
	C	300	350	350	350	400	400	400

"Dry-type" or "wet-type" is applicable for IEC type only.

Oil immersed termination (EB-0)

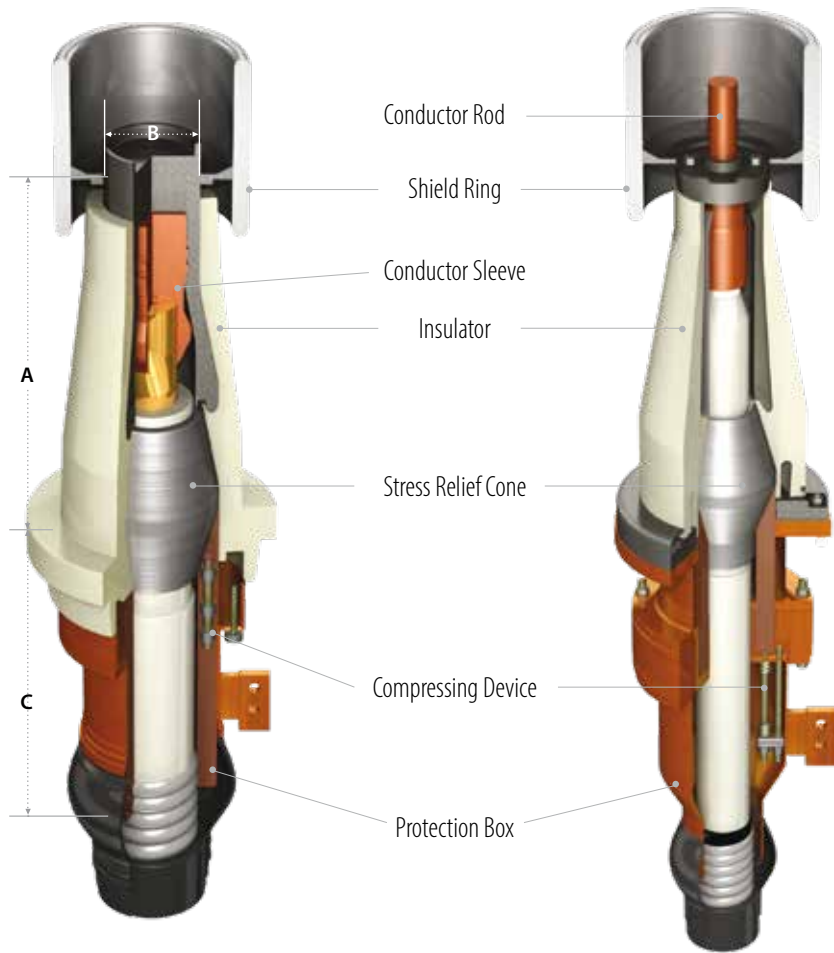

Plug-in type (IEC Type)

Compressing Leading
 Conductor Type
 (Non-IEC Type)

Ratings & Dimensions

Rated voltage	(kV)	60 ~ 69	110 ~ 115	132 ~ 138	150 ~ 161	220 ~ 230	330 ~ 345	380 ~ 400	
Maximum voltage	(kV)	72.5	123	145	170	245	362	420	
BIL	(kV)	325	550	650	750	1050	1175	1425	
Conductor size	(mm ²)	100 ~ 2500							
Approx. Dimension	A (Dry type)	(mm)	310	470	470	470	620	960	960
	A (Fluid type)	(mm)	583	757	757	757	960	1400	1400
	B	(mm)	110	110	110	110	200	250	250
	C	(mm)	300	350	350	350	400	400	400

"Dry-type" or "wet-type" is applicable for IEC type only.

Pre molded joint (PMJ)

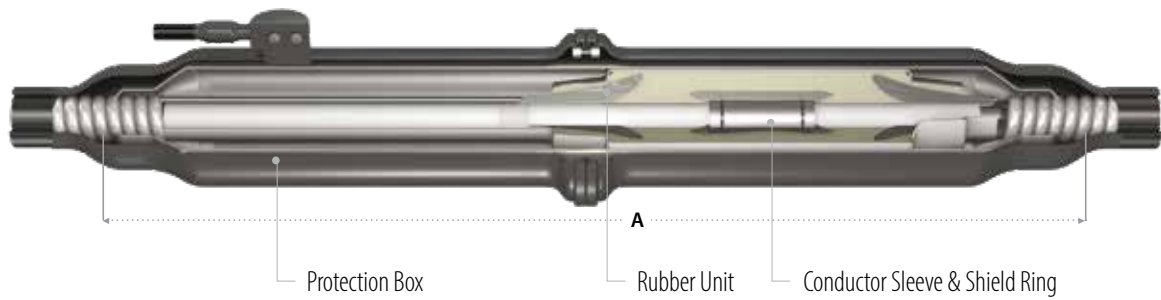

Normal Joint (NJ)

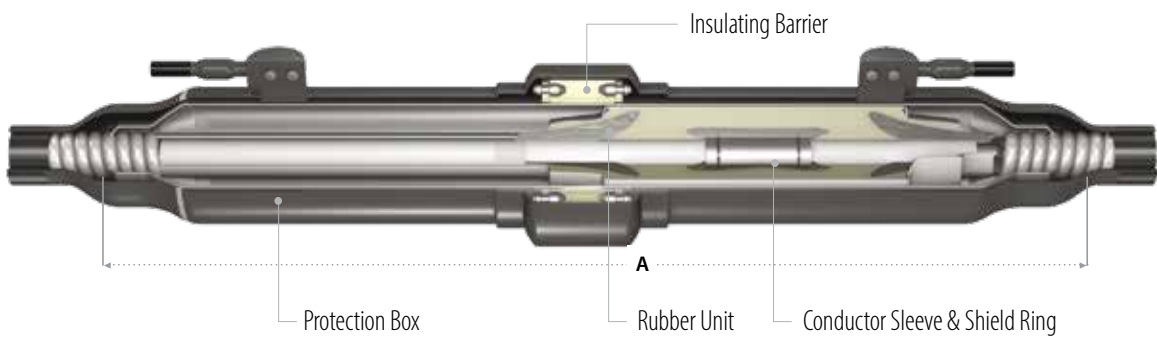

Insulation Joint (IJ)

Ratings & Dimensions

Rated voltage	(kV)	60 ~ 69	110 ~ 115	132 ~ 138	150 ~ 161	220 ~ 230	330 ~ 345	380 ~ 400	
Conductor size	(mm ²)	100 ~ 2500							
Approx. Dimension	Normal joint	Length (A)	1300	1300	1300	1300	1700	1900	1900
		Approx. Diameter	295	335	335	335	420	425	425
	Insulation joint	Length (A)	1300	1300	1300	1300	1700	1900	1900
		Approx. Diameter	305	345	345	345	430	465	465

Pre fabricated joint (PJ)

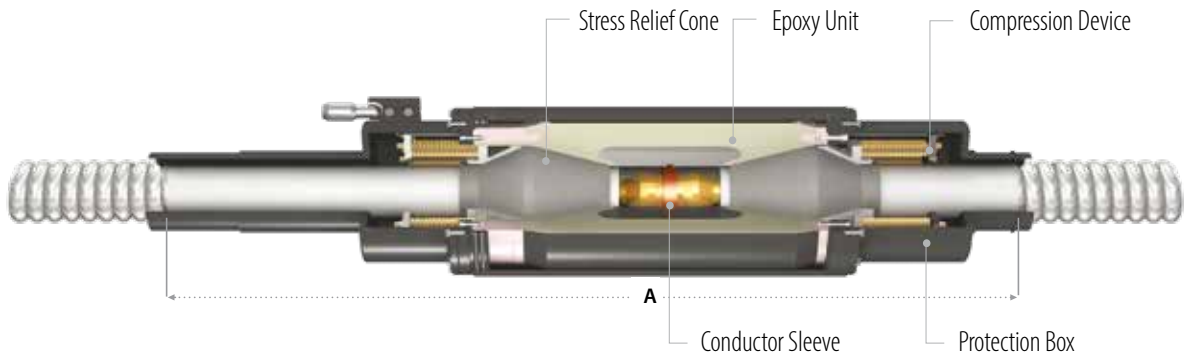

Normal Joint (NJ)

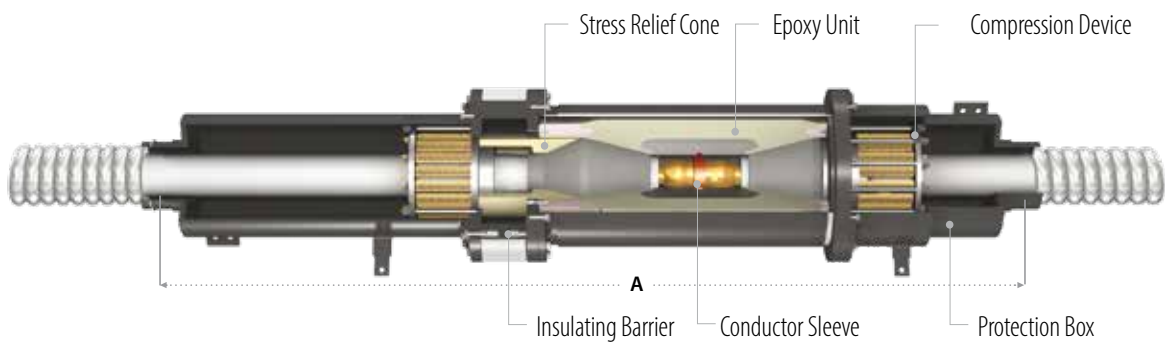

Insulation Joint (IJ)

Ratings & Dimensions

Rated voltage	(kV)	60 ~ 69	110 ~ 115	132 ~ 138	150 ~ 161	220 ~ 230	330 ~ 345	380 ~ 400	
Conductor size	(mm ²)	100 ~ 2500							
Approx. Dimension	Normal joint	Length (A)	1700	2000	2000	2000	2200	2200	2200
		Approx. Diameter	260	280	280	310	340	370	390
	Insulation joint	Length (A)	1700	2000	2000	2000	2200	2200	2200
		Approx. Diameter	270	310	310	330	360	380	400

Link box

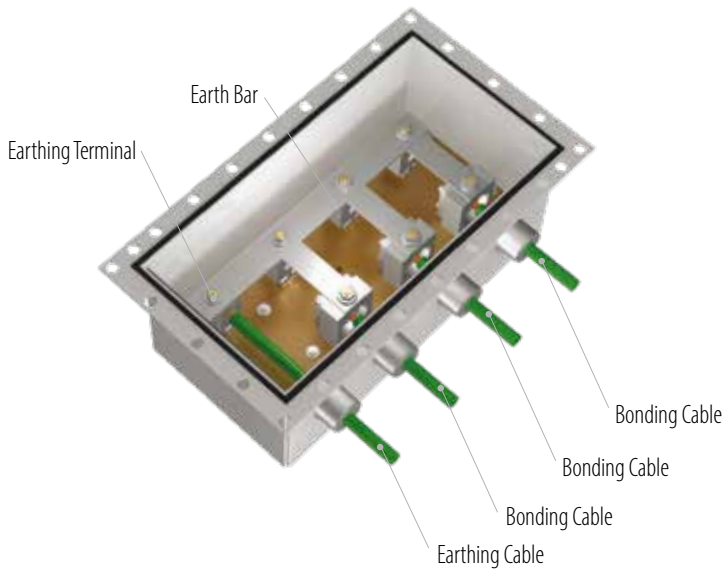

3-1 Way Link Box (Direct Buried Type)

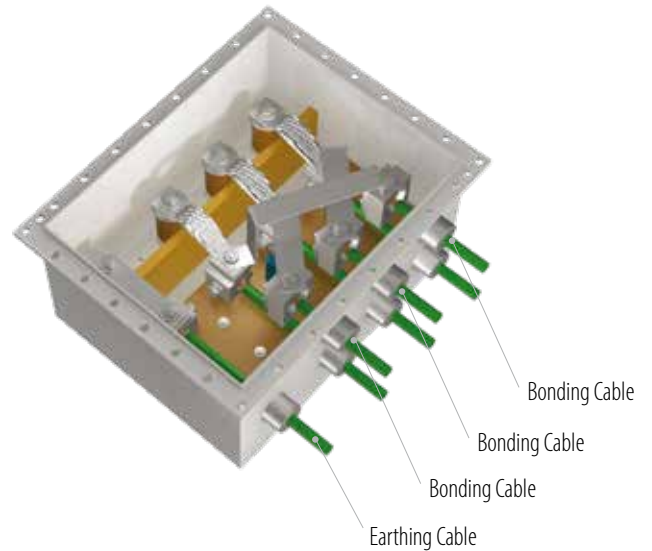

Cross-bonding Link Box

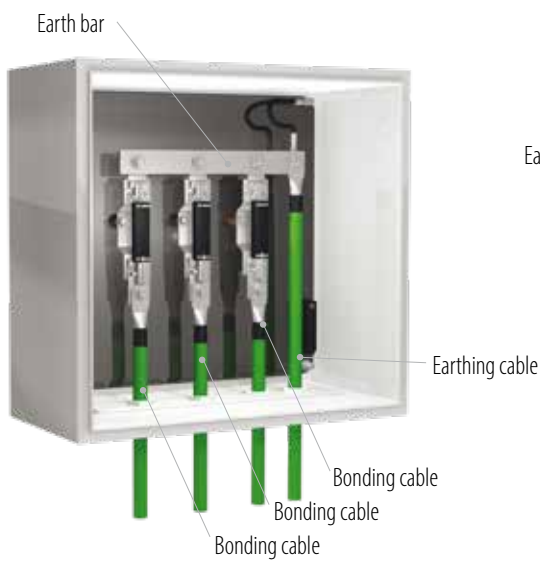

3-1 Way Link Box (Wall Mounted Type)

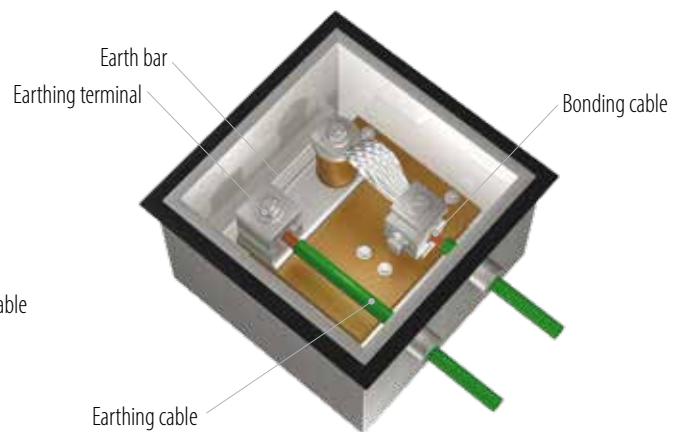

1-1 Way Link Box

Others

Transition Joints (XLPE-OF Cable)

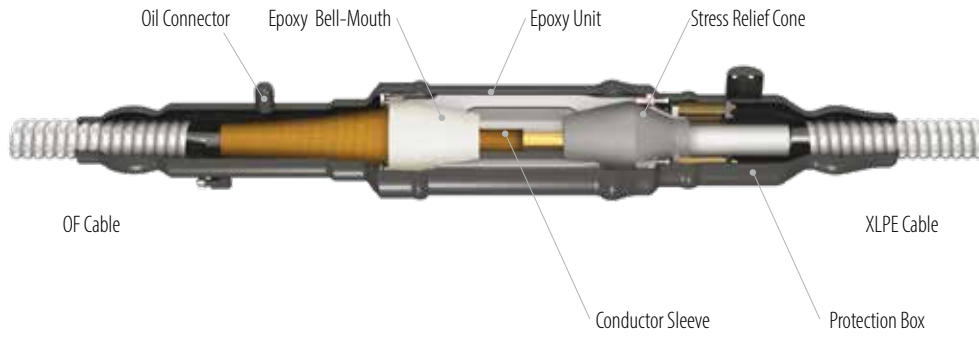

Normal Joint (TNJ)

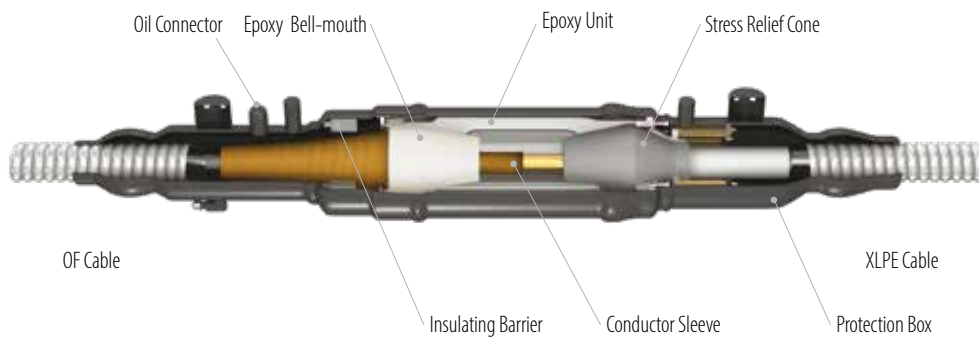

Insulation Joint (TIJ)

Cold Shrinkable Joint



700kV - Wall Bushing (Polymer type)



5. Quality Assurance System

Test Equipment



AC resonant testing equipment up to 900kV

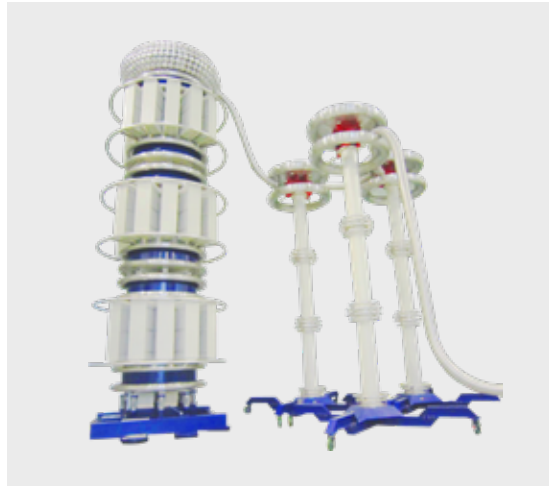

AC resonant testing equipment up to 750kV



Impulse testing equipment up to 3600kV

List of Test Certificates

Rated voltage	Conductor size	Tested items	Test lab	Spec	Issued	Remark
400kV	2500mm ²	Smooth type cable, PMJ, EB-A, EB-G	SGS	IEC 62067	2014	+ EQ Test(AEIC CS9)
		Cable, PMJ, EB-A, EB-G	KEMA	IEC 62067	2011	+ PQ Test
345kV	2500mm ²	Cable, PMJ, EB-A, EB-G	KERI	KEPCO Spec.	2009	+ PQ Test
	2000mm ²	Cable (with fiber), EB-A, EB-G Cable, PJ, EB-A, EB-G	KEMA KERI	IEC 62067 KEPCO Spec.	2008 2002	+ PQ Test
230kV	2000mm ²	Cable, PMJ, EB-A, EB-G	SGS	IEC 62067	2015	+ PQ Test
	800mm ²	Cable, PMJ, EB-A, EB-G	SGS	IEC 62067	2011	
220kV	2500mm ²	Cable, PMJ, EB-A, EB-G	CESI	IEC 62067	2014	
	2500mm ²	Cable, PMJ, EB-A, EB-G	KEMA	IEC 62067	2007	+ PQ Test
	1600mm ²	Cable(AL), PMJ, EB-A, EB-G	CESI	IEC 62067	2014	
161kV	630mm ²	Cable, PJ, EB-A, EB-G	KEMA	IEC 60840	2002	
154kV	2500mm ²	Smooth type cable, PMJ, EB-A, EB-G	KERI	KEPCO Spec.	2015	
	2500mm ²	Cable (with fiber), PMJ, EB-A, EB-G	KERI	KEPCO Spec.	2006	+ PQ Test
	2000mm ²	Cable, PMJ, EB-A, EB-G	KERI	KEPCO Spec.	2001	
	1200mm ²	Cabl	KEMA	IEC 60840	1999	
	600mm ²	Cable, PMJ, EB-A, EB-G	KERI	KEPCO Spec.	2001	
150kV	1600mm ²	Cable(AL), PMJ, EB-A, EB-G	CESI	IEC 62067	2014	
	630mm ²	Cable(AL), PMJ, EB-A, EB-G	CESI	IEC 62067	2014	
132kV	1200mm ²	Cable, PMJ, EB-A, EB-G, EB-O	SGS	IEC 60840	2008	
	630mm ²	Cable, PMJ, EB-A, EB-G, EB-O	SGS	IEC 60840	2007	
	300mm ²	Cable, EB-A, EB-G	SGS	IEC 60840	2004	
115kV	800mm ²	Cable	KEMA	IEC 60840	2002	
110kV	630mm ²	Cable, PMJ, EB-A, EB-G	IPH	IEC 60840	2009	
	800mm ²	Cable	SGS	IEC 60840	2003	
66kV	1600mm ²	Cable(AL), PMJ, EB-A, EB-G	SGS	IEC 60840	2015	
	1000mm ²	Cable, PMJ, EB-A, EB-G	SGS	IEC 60840	2007	

6. Cable Monitoring and Maintenance System

Schematic Drawing of Real-time PD sensing, DTS, and DRS

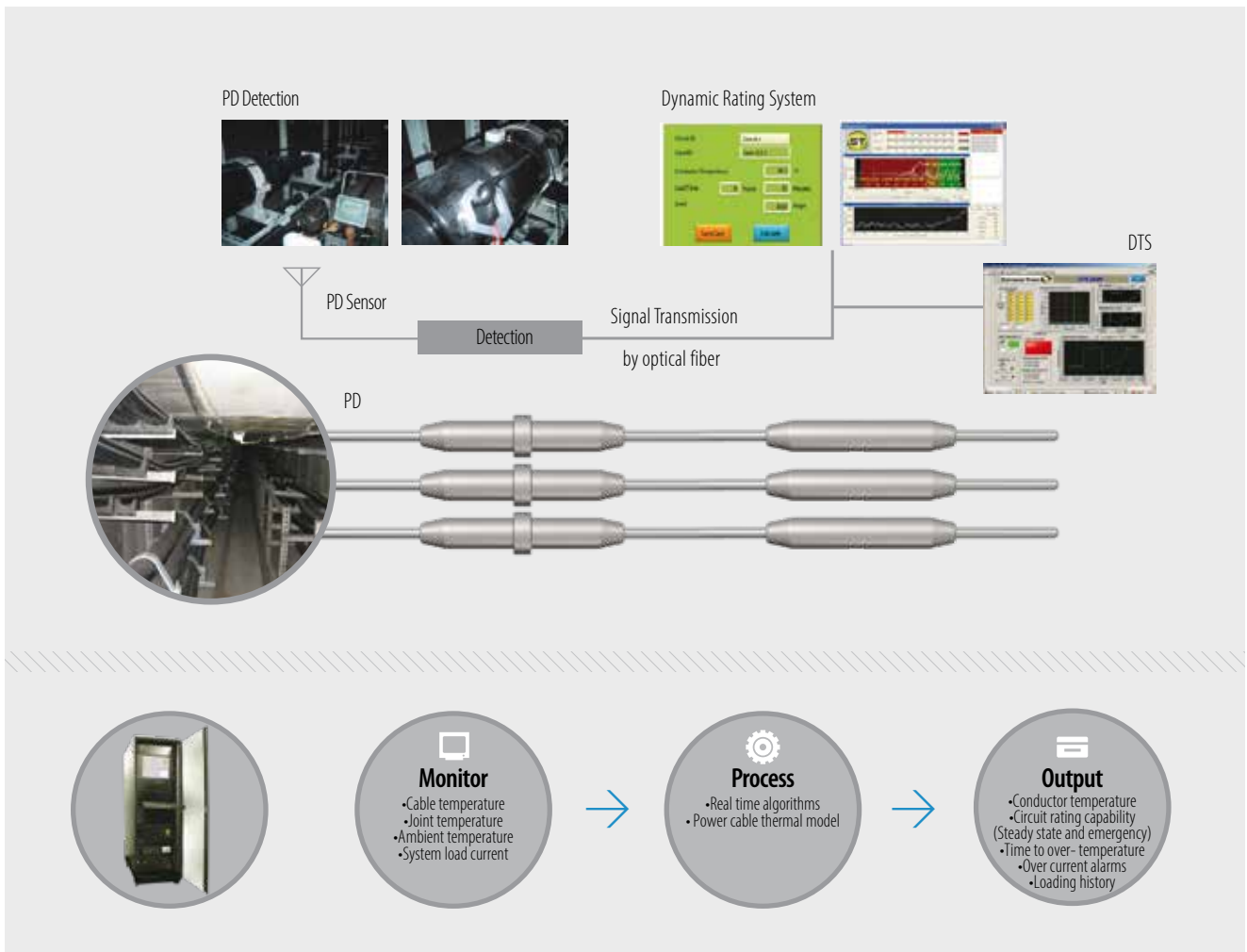

PD Diagnosis

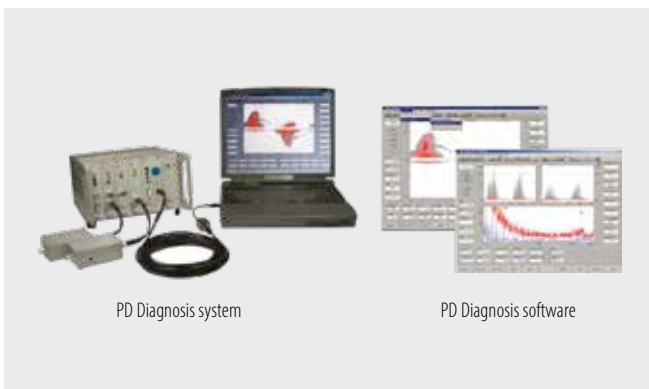

(U)HF PD Sensing Tools

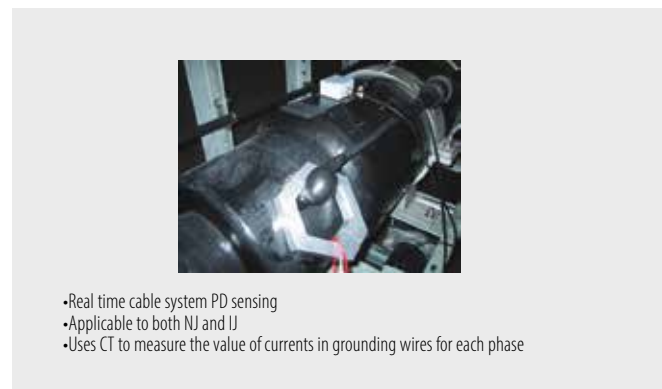

7. Cable Installation & System Design

1. Laying the Cable

	Direct Buried	In Underground Duct	In Air (Tunnel)
Advantage	<ul style="list-style-type: none"> - Low cost - Good heat dispersion 	<ul style="list-style-type: none"> - Convenient to expand or remove - Minimal exposure to external damage 	<ul style="list-style-type: none"> - Convenient for multi-line installations - Good heat dispersion
Disadvantage	<ul style="list-style-type: none"> - Inconvenient to maintain - Risk of external damage 	<ul style="list-style-type: none"> - High cost of installation - Expansion possibilities limited by permissible current 	<ul style="list-style-type: none"> - High cost

2. Maximum Cable Pulling Tension

Cable pulling tension is calculated using the following equation and must be within the conductor's allowable tensile strength.

- | | |
|---|-----------------------------------|
| 1) Using a pulling eye to conductor | 2) Using a stocking grip |
| - Copper conductor : 7kg/mm ² of conductor | - $T=0.357 D^2$ [kg] |
| - Aluminum conductor : 4kg/mm ² of conductor | - D : Cable overall diameter [mm] |

3. Minimum Bending Radius

The data on the table below shall be considered in order to install cables without any damage on their electrical and physical properties.

Minimum Bending Radius / D : Cable diameter

Cable type	wire screen	Lead sheath	Corrugated Sheath	Smoothed AL	Armoured
Min. bending radius	20D	20D	18D	20D	15D

4. Maximum Sidewall Pressure

$$P = T / R$$

P : Maximum sidewall pressure [kg/m] T : Maximum pulling tension [kg] R : Minimum bending radius [m]

5. Bonding Systems

Typical Bonding Systems

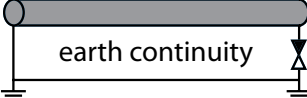
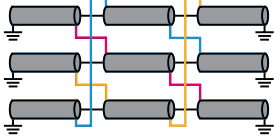
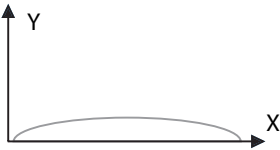
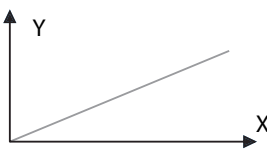
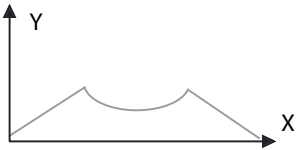
	Solid Bonding System	Single Point Bonding System	Cross Bonding System
Characteristics	<ul style="list-style-type: none"> - Sheath induced voltage is zero - Low permissible current caused by circulating loss 	<ul style="list-style-type: none"> - Suitable for short routes generally without any joints 	<ul style="list-style-type: none"> - Suitable for long routes with two or more joints
Diagram			
Induced Voltage			

6. ILJIN Cables after installation



8. Current Status of R&D

154kV Eco-friendly Polypropylene Insulated Cable



[154kV CU/PP/Corr.AL/PE.2500SQMM]

- Increased demand for cables that can increase transmission capacity due to higher capacity and efficiency of power cables
- Improvement of transmission capacity due to increase in normal operating temperature
 - Allowable current increased by more than 10% compared to equivalent XLPE cable
- Possible to reduce construction costs by replacing small-sized PP insulated cable
- Possible to minimize failure because of no by-products
- Possible to reduce emission of greenhouse gas by reducing power usage during the manufacturing process
- Completed PQ test according to IEC 60840 at 110°C (KEMA)
- Completed green certification for cable manufacturing process
- Pilot project in progress in connection with domestic transmission lines (Planned to replace 154kV XLPE cable)

Contents	Details
Conductor Cross Sectional area	154kV 600~2500SQ (Including 1600SQ)
Conductor Temp.	110°C
Test Conditions	Type Test (115~120°C , 2U0, 20Cycle)
	PQ Test (110~115°C , 1.7U0, 180Cycle)



[Type test loop of 154kV PP insulated system]



[PQ test loop of 154kV PP insulated system]



[Type Test Report]



[PQ Test Report]



[Green Certification]

320/525kV HVDC XLPE VSC type Land Cable system

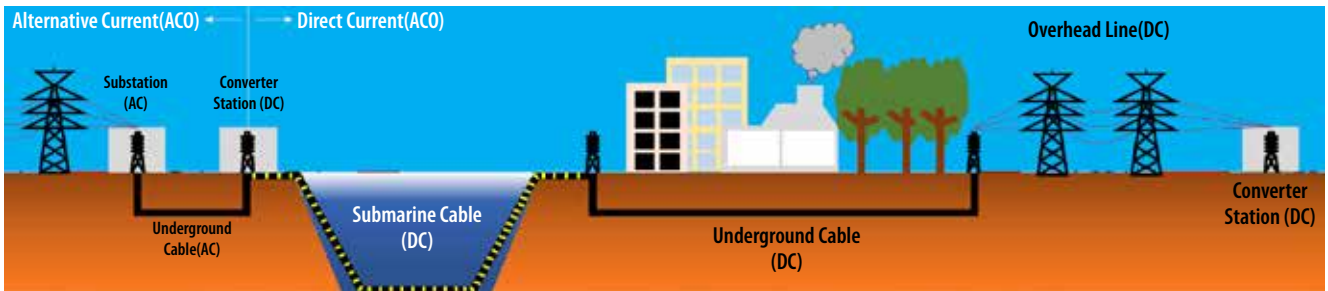

[HVDC Submarine & Underground Cable System Project Scheme]



[±320kV XLPE 2500SQMM]



[±525kV XLPE 2500SQMM]

- The proportion of land cable system in the HVDC system is increasing
- 320/525kV XLPE VSC type extruded cable is designed to maintain a 40-year lifetime
- Smooth Aluminum sheath is applied to favor long-distance transmission
- Production of sophisticated products by applying the highest grade XLPE and VCV process considering space charge accumulation
- Completed 320kV Type test and Pre-qualification test according to IEC 62895 standard
- Ongoing 525kV Self-verification test according to CIGRE TB 852 (with LCC type, VSC type)

Description	Condition	Remark
Heating cycle	12cycle -592kV	1.85U0
	12cycle +592kV	1.85U0
	3 days CH +592	CH : Continuous heating
Superimposed impulse voltage test	± SI 420kV at DC -320kV	10h Pre-stress
	± SI 420kV at DC +320kV	
	+LI 780kV at DC -320kV	
	-LI 780kV at DC +320kV	

[±320kV VSC type XLPE cable system Type test procedure]



[±320kV VSC type XLPE cable system Type test loop]



[±320kV VSC type XLPE cable system PQ test loop at KEMA FGH]



[±320kV VSC type XLPE cable system Type&PQ test reports]

ILJIN Electric Global Network

Seoul Sales Office

07789, 15, Magokjunang 14-ro,
Gangseo-gu, Seoul, Korea
Tel) +82-2-3777-8372

Manufacturing Plant

Hwaseong 1st Plant (Headquarters, Switchgear)

905-17, Mannyeon-ro, Hwaseong-si,
Gyeonggi-do, 445-380, Korea
Tel) +82-31-220-0500

Hwaseong 2nd Plant (Power Cable)

905-64, Mannyeon-ro, Hwaseong-si,
Gyeonggi-do, 445-380, Korea
Tel) +82-31-220-0900

Hongseong Plant (Transformer & GIS)

467, Sandan-ro, Galsan-myeon, Hongseong-gun,
Chungnam-do, 350-852, Korea
Tel) +82-41-413-3000

Ansan Plant (SCR)

14 Block, 21, Neungan-ro, Danwon-gu, Ansan-si,
Gyeonggi-do, 425-100, Korea
Tel) +82-31-8085-7711



• Head Office



• Hwaseong 1st Plant



• Hwaseong 2nd Plant



Overseas Branch Offices

Singapore Branch Office

8 Boon Lay Way, #09-05 Tradehub 21,
Singapore 609964
Tel) +65-6659-0624
E-Mail) billy@iljin.co.kr

Saudi Arabia Branch Office (Riyadh)

Al Imam Saud Bin Abdulaziz,
Rd - Al Nuzha, Riyadh, Kingdom of Saudi Arabia
Tel) +966-11-499-2344
E-Mail) daniel.park@iljin.co.kr

Kuwait Branch Office

Block 4, Street 402, House No.4,
Egalia, Kuwait
E-Mail) uhm@iljin.co.kr

Overseas Subsidiary

ILJIN Electric USA, Inc.
15995 N. Barkers Landing Rd, Suite 310,
Houston, Texas 77079
Tel) +1-832-300-3339
E-Mail) yongju.shin@iljin.co.kr



• Hongseong Plant



• Ansan Plant



• ILJIN Industry complex



ILJIN ELECTRIC CO., LTD. CABLE DIVISION

Head office 07789, 15, Magokjunang 14-ro, Gangseo-gu, Seoul, Korea | Tel : +82-2-3777-8372 Fax : +82-2-707-9685
Factory 905-64, Mannyon-ro, Hwaseong-si, Gyeonggi-do, 445-380, Korea | Tel : +82-31-220-0913 Fax : +82-31-220-0909
Website www.iljinelectric.co.kr
ILJIN Family ILJIN Electric / ILJIN Diamond / ILJIN Display / ILJIN Materials / ILJIN Steel / ILJIN Unisco